



j. Newcombe Hodges

A Primer For Tomorrow

An Official Human Race User Manual
For Humans Assembled Between 1910 - 2100.



Tamashii – A Primer for Tomorrow

ISBN 1-57121-018-0

COPYRIGHT© 2003 j.Newcombe Hodges

Smear, LiquiCode, Tamashii Engine, Tamashii RE, Snow and the Tamashii logo are trademarks and/or property of Tamashii Corporation. All rights pertaining to text, theories, designs and graphics are reserved.

All other copyrights and trademarks displayed are the property of their respective owners.

Distribution or reproduction of this document, or the information contained herein, is strictly prohibited without written permission from j.N. Hodges, Tamashii Corporation or Stone Arbor Corporation.

To Marcia: The Center of My Universe.





Table of Coverage

Preface	
Chapter 1	The Silicon Plateau The Growth of Technology
Chapter 2	Elementary Frequencies – Tomorrow's Alchemy Particles – Photons - Quarks What is Quantum Physics all about? Bells and Whistles Elementary Particles Quarks
Chapter 3	Gravity and Light Element Configurations Gravity - Applications and Implications
Chapter 4	The Intelligent Universe Photon Events Electrostatic to Electromagnetic Electricity Transformer Electrostatic
Chapter 5	Putting It All Together The One-Second Universe Radiant Energy Power Systems TeraHertz Imaging Bio Computers
Chapter 6	Speculation and Observations Teleportation Life Frequency Time Manipulation Time Travel Shadow People Ghosts Past Lives The Soul Soul Storage

Preface

Once upon a time, I promised myself that I would:

- Never let mediocre minds stand in my way.
- Never think that something is impossible to accomplish.
- Never write a book that begins with, 'Once upon a time'.

Two out of three is not too bad.

It was over two decades ago, when I stood before 'an assembly of outsiders' and projected a future that would revolutionize an industry. That Gathering was the *First Robotics Conference*. I presented concepts, strategies and industrial forecasts for that small, eager audience of scientists, designers, experimenters . . . and visionaries. Many of these *Futurists* went on to set standards for a billion-dollar industry, designing countless industrial and life-saving devices. These individuals eventually placed robots on Mars, in the battlefields and under the oceans of the World.

And, I must admit, there were more than a few 'crackpots' present in that conference room, so far ago. Well, they were considered crackpots then . . . most call them millionaires, today.

But, in the late 70's, one never talked about Robots (out loud anyway). Visions of mechanical men, trudging to the workplace to take away assembly jobs, ran through the minds of workers, everywhere. The list of personal, economic and working-class social fears grew, as first-generation robotic systems (pick-and-place) began to appear in the workplace.

It was a very anxious time for the developers, innovators and visionaries. An industry, in its infancy, was beginning to 'go to

work'. And we really didn't even know how to walk. We just knew we were in a technological stampede, we were leading it and we had better learn to run.

Chips, computers, software, tele-presence controls, carbon-fiber, servo and step drives, modems, computer vision, voice recognition . . . the list of technologies, which evolved from automation in the workplace, has provided millions of jobs, all over the planet.

Humans just need that small spark, to build the fires of change. One mind passing on an idea to another. Whether that idea was jotted down on a napkin, or, appeared on a cave wall, the results are the same. The course of Humanity changes forever.

Instead of a cave wall, we are now etching our ideas on computer monitors. Same hands, different tools.

I have been conducting research, blowing up experiments and patenting *things* since 1975, but never had the resources to jump in with both feet, until 1985. It was while I was working on a Black Project, where whispers of Electro-gravatics were felt, that I began to look 'under the covers' of popular physics.

I initially found little. Just some patents by Nikola Tesla and TT Brown. A few articles about a Dean, Keely and Searle. Hamiltonian and Newtonian approaches to How . . .but, never a Why.

That was not good enough. I began digging for the Why of things, and have not let up for these many years.

Oh, the wondrous things I have discovered. The simple, elegant secrets, that were revealed to me, have dissolved the half-truths that I had been taught.

I have laughed among the innocents and cried for the cover-ups that erased many important paths and destroyed many important lives. I have seen the blueprint that the very stuff of stars are made from.

I have called my research, and this Book, *Tamashii*. From the Japanese word meaning *Soul*. I hope you will be able to see the connections.

I am now standing, as I have before, before 'an assembly of outsiders'. That would be you, good reader – as an individual wanting to know Why and not settling for just How. As you will see, not just a *single* industry (as in Robotics) could arise from the following presentations, but a new direction in which scores of industries and careers could arise from our present Silicon Plateau.

After reading this book, I am confident that the final analysis will reveal that: not only are the concepts, devices and theories, contained within these pages, possible, but will begin appearing in various forms, within 20 years.

The following material was written for the scientists of tomorrow, who are the students of today. And for the 'average Joe and Jane', who just wants to know Why the Universe works and What is to come.

Present K-12 education curriculums do not fully prepare students for any careers, outside of service industries. What a student wants to be "when they grow up", does not come into play until one enters college. And this opportunity is only available if a student can afford the continued education experience. And many times the money and time are wasted as a defined path for a career is never developed. The Spark is never generated. The Passion is never realized.

I hope that a portion of this book, or even one idea, may provide a spark or fan a passion within a young mind. Or, fuel the support of an unrecognized inventor, who knows he can do it! I

believe in tomorrow. I believe that everything in this book will come to pass. I believe in the spirited imaginations and creativity of students, who are looking for their *own* path to tomorrow.

It only takes one person to change civilization.

.....

"Space, or the Void, has an equal right with reality, or Being, to be considered existent. The Void is a vacuum, an infinite space in which moves an infinite number of atoms that make up Being. These atoms are eternal and invisible; absolutely small. So small that their size cannot be diminished; absolutely full and incompressible, as they are without pores, and entirely fill the space they occupy; and homogeneous, differing only in shape, arrangement, position and magnitude. Particles that make up the light, and even the Soul.
- *Democritus 400 BC*

"If I knew everything, I wouldn't be here."
- *j.N.Hodges* -Last Wednesday

"Any sufficiently advanced technology is indistinguishable from magic."
- *Arthur C. Clarke*

Chapter One

THE SILICON PLATEAU

Off and On.

There it is, the answer to everything – Off and On.

I could end this narrative now, having revealed the ultimate secret to the inner workings of all existing technology, but what happens between Off and On is what this book is addressing.

The present High-Tech era is nearing the end of Act One, and soon, all the players will begin repackaging their electron-based props and repainting their facades and backdrops, up there on The Silicon Plateau. That vast, nearly empty theater, where everything that used to switch Off and On, now remains Off. (The address is 700 GigaHertz, if anyone asks).

The Technoids have pushed an electron as fast as it can go, over the shortest path possible, within an ideal silicon environment. However, the constraints of Time and Space have placed a serious ceiling over any future technology breakthroughs needed to advance Humanity into the next millennium. The One-Second Universe has been pushed to its limits.

In order to enter the next phase, of High-Technology growth, we must now develop new tools to continue the climb. But, the Future can only be viewed through shadows of the Past.

I need to take you back a few millennia and retrace some technology paths, in order to fully explain where we are today and where we should be going, in the very near (and very far) future. Back to when the world's first Discoverer,

Ogg, happened upon a burning tree, most likely the result of a lightning strike.

It is assumed that Fire was discovered before language and writing, so any record of the event can only be conjecture. Although, some phonetic ill iterations may have been uttered that day, as Ogg surely burned himself, when he grabbed the wrong end of the flaming stick.

The acceleration of the introduction and application of any new technology into society is dependant upon demonstration and explanation. The quickest route to acceptance of any innovation is through entertainment or providing an immediate solution.

I am sure that when Ogg entered his Clan's dark cave, carrying that flaming stick, very few asked, "Great, what does it do?" They wondered, 'What else can it do?' And, "Wait till the Clan, in Cave 7, gets a load of this!"

As in all cases of technology discovery and development, parallel events occur that result in near simultaneous appearance of new offerings, often thousands of miles apart. And it began with Ogg and his Fire. Perhaps an identical set of circumstances resulted in the introduction of Fire to hundreds of other Clans, around the globe, within years of each other. Each developed their own uses for the new technology – resulting in hundreds of varied ways of illuminating, cooking, heating, creating ceramics, smelting, communicating, farming, glass making . . . the list is still growing.

The focus of this example is that each of the 'discoverers' developed specific solutions to their own problems and environments, using Fire. They found applications, for the technology, that would enable them to improve their work, play and/or existence, independent of any outside influences.

In addition, upon an encounter with another Clan, these specific applications, of the technology, would be eagerly

passed around. In Ogg's day, the existence and varied uses of Fire was passed by word-of-mouth or physical interaction, so it was years before any new application was introduced, from the outside. The growth of the Fire Industry took centuries. As did all breakthroughs, until we developed ways of passing the word faster.

You will notice that I have not applied the term "Inventor" to an individual, only "Discoverer". Invention is the act of improving on an existing idea. Moreover, it is safe to say that very few single individuals have ever invented anything, on their own.

Envision the person that had the 'original' idea, or perhaps the thousands of people, that each exclaim, "I thought of that idea years ago! It belongs to me!" Are they the Inventor?

Enter the Model Builder, who actually put together a working contraption of the idea, often by accident or from modified plans of a similar idea. Is this the Inventor?

And finally, the ever-present business person/entrepreneur, who commercialized the idea or put up the money for the manufacturing and distribution (just sign here . . . here. . . here).

Nope, not a single Inventor present.

The whole process of technology development is nothing more than nailing two, or more, existing technology 'sticks' together to get a 'new one'. There are numerous developmental steps and a long string of "inventors" involved with bringing any idea to fruition.

However, an idea or technology that emerges, without the influence of any technology before it, is known as a Basic Technology. These are "Discovered."

The list of Basic Technologies is very short. Think of them as the Adam and Eve of technology. Fire, Magnetism, the Elements, Photons, Gravity, Electricity and Life.

When Ogg walked into the cave, with the Fire, he was presenting Basic Technology.

When his Clan wanted to see what else could be done with the Fire, that was the beginning of Basic Science.

When they wanted to show it off to the Clan in Cave 7, that was just being Human.

Picture, in your mind's eye, an upside-down Pyramid.

Alternatively, just look at Fig. 1.

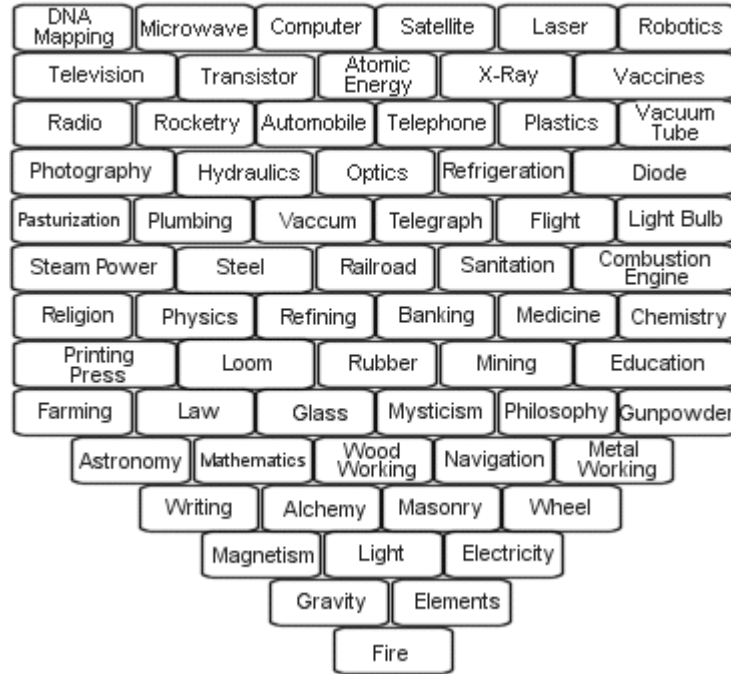

Figure 1 Technology Pyramid #1

At the bottom, a small point representing Ogg's discovery of Fire. As the Pyramid grows taller, it also expands outward,

displaying humanity's technological growth, up to today's vast array of widgets.

The first three layers are Basic Technology and not one area of technological development, above these layers, could exist without this Basic Technology foundation. Every technology, moving up the Pyramid, contains the technology layer below them, with an additional ingredient or 'new technology stick', which makes it worthy of being in the stack.

The graphic only illustrates a small portion of Humanity's achievements and only in approximation of the time of the technology's introduction. Nevertheless, the most important factor in this Model, is that the whole Pyramid *only* exists in a limited One-Second Universe.

Frequency Chart, up to H¹

Hydrogen	0.302181342	EHz	0.992094535	nm
Atomic Standard □	3.484923	EHz	0.086025562	nm
Electron Compton Wavelength	1.235748	EHz	0.242599995	nm
Free Electron Formation			0.49	nm
Gamma Rays	299.79	PHz	1.000008199	nm
X-Rays	29.9979	PHz	9.993781501	nm
CO2 Laser	28.282	PHz	10.6001152	nm
Vacuum UV	26.996	PHz	11.10506957	nm
UVC	1.4989	PHz	200.0083115	nm
UVB	1.0706	PHz	280.0228452	nm
UVA	951.721	THz	315.0003605	nm
Upper Visible Light	749.481	THz	400.0000775	nm
Lower Visible Light	428	THz	700.4496685	nm
Far Infrared	299.792	THz	1.000001528	m
Yag Laser	282.823	THz	1.060000276	m
Infrared Radiation	29.979	THz	10.00008199	m
Highest Microwave	11.992	THz	24.99937109	m
Near Infrared	2997.92	GHz	100.0001528	m
Hydrogen Line	2110.6	GHz	142.0413428	m
EHF	299.795	GHz	999.9915212	m

SHF	29979.25	MHz	0.009999999	m
UHF	2997.925	MHz	0.099999986	m
VHF	299.792	MHz	1.000001528	m
Microwave	13.56	MHz	221.0858836	m
HF	2997924.6	Hz	99.99999937	m
MF	299792.46	Hz	999.9999937	m
LF	29979.246	Hz	9999.999937	m
Highest Audible (Human Female)	25000	Hz	11991.69832	m
VLF	2997	Hz	100030.8502	m
Lowest Audible	300	Hz	999308.1937	m
EMF-US	60	Hz	4996540.968	m
EMF-Europe	50	Hz	5995849.162	m
ELF	30	Hz	9993081.937	m
Circumference of the Earth	7.451	Hz	40235197.71	m
One Second - Speed of Light	1	Hz	299792458.1	m

The Tamashii story begins at the first entry of the Frequency Chart (Hydrogen) and continues up. However, the Basic Technology foundations remain the same.

I receive calls from some of the top professionals, in the High-Tech world, many on the verge of unemployment, asking, “What is next? The whole technology field is stagnant.” Or, “Nothing is fun, anymore. Where is the next breakthrough going to take place? How can *we* be prepared?”

First, the *world* is not prepared for a breakthrough, into the next level of technology. It will be as disruptive as the Industrial Revolution was to the cultures of the 19th Century.

The Advertisement

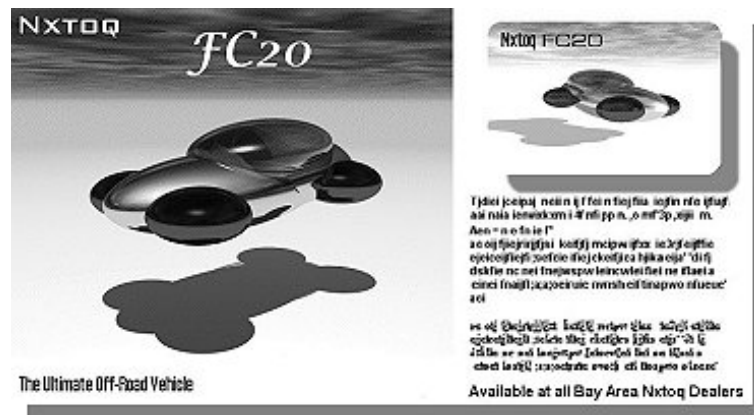

Figure 2 The FC20 Advertisement

Imagine this advertisement, for the *Nxtq FC20 Flying Car*, running in next Sunday's newspaper without any previous announcements or related devices leading up to the introduction.

This is not unlike Ogg, walking into the dark cave with a flaming stick.

The world's societies would be turned upside-down, as well as their economies, within a very short time.

Think of the industries that would need to be modified or created.

Anti-gravity Drive parts manufacturing and related service companies would grow overnight.

Highways would need to be redesigned to look more like golf course fairways, as well as raising or removing most Overpasses (Flyovers).

The Wheel and Tire industry would be in serious trouble.

Overland freight, trains and bus operations would need to be completely restructured.

What if the FC20 is electrical? Serious problems with the oil industries.

What kind of license would you need to drive/fly one of these things? When you are on the ground, you need a driver's license. When you fly a plane, you need a Pilot's license. However, you will only be 2 or 3 feet up. Administrative nightmares will abound. Entirely new governmental layers would need to be created to deal with the new technology, including massive upgrades to existing Law Enforcement agencies.

What would happen to the existing automobiles and the multitude of manufactures, service businesses and related industries? The automotive world would be in chaos.

Could a technology, like the Flying Car, suddenly emerge today from the Corporate World?

Not really. The development of any technology requires the baseline of another technology. In order for a device, like the Flying Car, to suddenly emerge, hundreds of other technology branches would be required, all with known products. Most Corporations focus on a specific market niche and established business processes. An automobile company would not risk rocking their own economic boat to attempt such a feat.

Where would it come from? Most likely, an entertainment company or a Toy Manufacturer.

As in all new technology, a toy or other form of entertainment device, based on the technology's principles, will appear first.

If the Sunday Paper ad would have been for a *toy* Flying Car, with some sort of entertaining Anti-G drive system, the technology would be accepted overnight. No questions asked, for it caused little danger to any cultures and it was a 'Neat Thing'. However, small red flags would have gone up for all parties concerned with the 'real world' – for a new mode of transportation *could* be on the horizon and aligning businesses could participate in the creation or elimination of millions of jobs. And a ton of bucks.

However, in this paper-pusher age, by the time the real Flying Car would be introduced, a dozen other copies would be on the market. Thanks to the wasted weeks/years allocated to modern economic tools for analyzing the consumer demand and ignorant project managers, manipulating design meetings, channeling Partnerships (giving away the ideas) and identifying the explanatory variables that should be included in a model of the demand for the new technology. This is the phase, where mediocre minds, kill most breakthroughs.

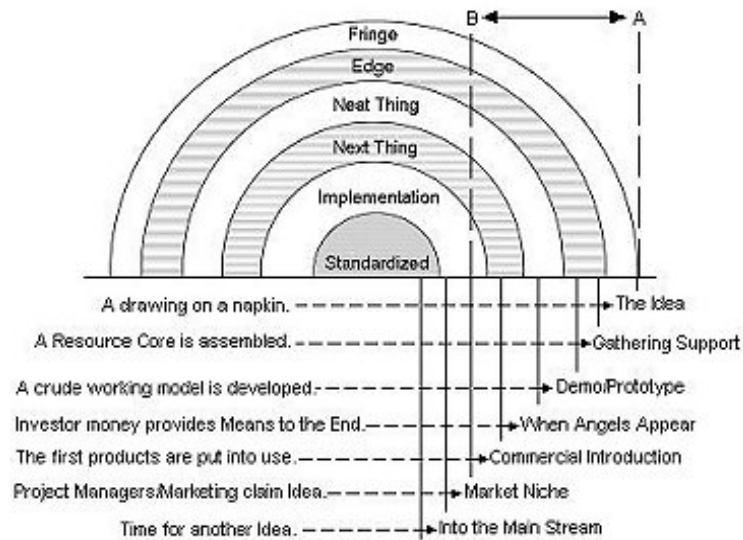

Figure 3 Evolution of an Idea

The above graphics illustrates the evolution of an idea, from conception to standardization. Most corporate Marketing Managers envision that a miracle happens, between A & B. Actually, this is where the real fun can be found. (By the way, when an idea gets to B, I move back to A).

The Corporate World was never structured to deal with a technological breakthrough.

There are four obstacles that need to be cleared for any new idea to become a 'household word'. Time, Resources, Culture and Personal Agendas.

Could a single individual have built the Flying Car, set up the Dealerships, handled the Marketing, etc? Maybe not a single person, but a small, creative, aggressive group (such as The Nxtq Company) could have. But, in order to accomplish this feat, they would to have enter the region above the

Silicon Plateau. Up to a point where the Flying Car is *not* their only focus. That product would have been a result of Gravity Push and Radiant Energy research. A single company, with knowledge of (at least) the first three layers of the following graphic, should be monitored – *very carefully*.

Below is the New Technology Pyramid, based on probable advancements in Technology in the next 100 years. This graphic displays the shadows of the future, only if a significant breakthrough and acceptance in Particle-Level frequency replication (~100 EHz Signal Generator) can be established, pushing us above the Silicon Plateau.

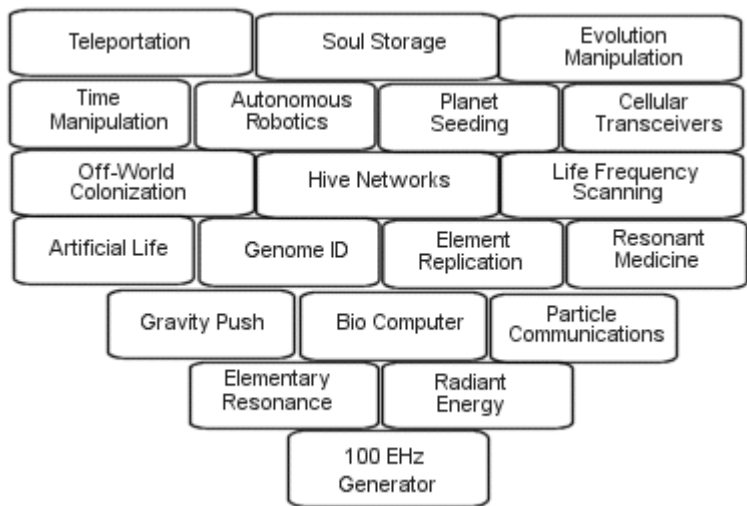

Fig. 4 Technology Pyramid #2

Manipulating the moments, which exist between the seconds, is what Tamashii is all about. In addition, those moments are countless and always in existence, based on the actions and reactions of Particle oscillations.

I have structured, the rest of this book, as a climb up the Technology Pyramid #2 (Fig. 4). I will begin with the Basics of Wave-to-Particle formation, the building of Electrons and Atoms and provide a clear understanding of Why everything works, beyond the One-Second Universe.

This will provide you with a clear understanding, of the inner workings, of the first and most critical component, in the formation of the new Pyramid. The 100 EHz generator.

I shall then continue, up the Pyramid, to explain how each new technological advancement will emerge, from that building block. And how it will affect our Cultures, our Resources and our Individualities.

This is not Science Fiction, but Science Fact. It is only a matter of Time.

Chapter Two

ELEMENTARY FREQUENCIES

In 1913, a research scientist named H.G.J. Moseley, M.A, published a paper about an experiment he performed to document the wavelengths (frequencies) of the 63 known elements (at that time), between Aluminum and Gold. His experiment was the forerunner to modern day spectrum analysis as he demonstrated that the elements emitted characteristic X-rays. These emissions were *independent* of the physical or chemical state the element was in. This was the signature of the element.

With the discovery of isotopes of the elements, it became apparent that Atomic Weight was *not* the significant player in the periodic law as Mendeleev, Meyers and others had proposed, but rather, the properties of the elements varied periodically with the Atomic Number.

Moseley was killed in action at Gallipoli in 1915.

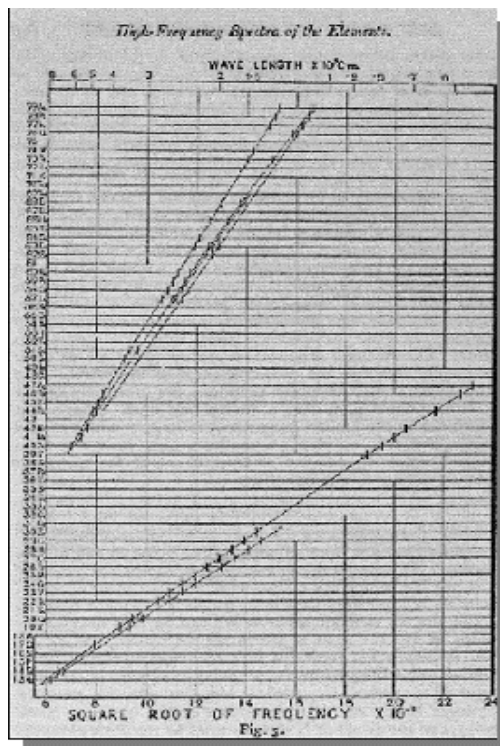

Fig 5 H.G.J. Moseley

In 1978, I took up Moseley's work and began research into the remaining elementary frequencies. My results proved to be more than just conclusions to Moseley's findings.

I found that the most useful information, of each element, would be the individual Photon wavelength of each. If this could be charted, the superposition and beat properties would allow Particle manipulation, above and beyond chemical and metallurgical processes. But, a signal generator, capable of emulation within the Photon range, would need to be developed.

There is evidence that Moseley had revealed some threads of the basic fabric of the Universe, but the existing minds of the time were unable see beyond Newton. Moseley's Chart is below.



As you can see from the chart, Moseley charted 66 elements, between Aluminum and Gold. (In 1913, only 63 elements were known to exist in this span). His findings indicated that an element existed (or should exist) at position 43, another at 61 and a third placed at 75. It wasn't until years later that these elements were discovered [#43 Technetium, #61 Promethium, #75 Rhenium]. Fortunately, Moseley had given the chemists a road map on where to find them.

As I mentioned, I continued this mapping of individual Photon wavelengths, which lead to the following Frequency Chart, showing each frequency bandwidth of *today's* known elements.

These are arranged according to the Frequency/Wavelength of each known element.

The Tamashii Frequency Chart					
Names in Red – Artificially prepared					
#	SmbL	Element Name	Weight	Spectrum Freq EHZ	Wavelength nm
	∞	Life Forms		Chapter 5	Chapter 5
94	Pu	Plutonium	244.06	73.16723552	0.004097359
92	U	Uranium	238.03	71.35948976	0.004201158
86	Rn	Radon	222.0176	66.55910034	0.004504154
90	Th	Thorium	232.038	69.5631361	0.004309646
96	Cm	Curium	247.0704	74.06972936	0.004047436
100	Fm	Fermium	257.0951	77.07505422	0.003889617
88	Ra	Radium	226	67.75309553	0.004424779
99	Es	Einsteinium	254.0881	76.17357968	0.003935649
87	Fr	Francium	223.0189	66.85928207	0.004483932
98	Cf	Californium	251.0796	75.27165544	0.003982807
95	Am	Americium	243.06	72.86744352	0.004114217
89	Ac	Actinium	227.0278	68.06111822	0.004404754
93	Np	Neptunium	237	71.05081257	0.004219409
97	Bk	Berkelium	247.0703	74.06969938	0.004047437
101	Md	Mendelevium	257.0956	77.07520412	0.00388961
91	Pa	Protactinium	231.0359	69.26271453	0.004328338
81	Tl	Thallium	204.37	61.26849104	0.004893094
83	Bi	Bismuth	208.9804	62.65065208	0.004785145
80	Hg	Mercury	200.59	60.13527728	0.004985301
76	Os	Osmium	190.2	57.0204384	0.005257632
78	Pt	Platinum	195.09	58.48642128	0.005125847
102	No	Nobelium	255.0933	76.47493059	0.00392014
77	Ir	Iridium	192.2	57.6200224	0.005202922
79	Au	Gold	196.97	59.05003024	0.005076923
82	Pb	Lead	204.375	61.27008362	0.004892966
104	Rf	Rutherfordium	259	77.646128	0.00386101

84	Po	Polonium	208.989	62.65323029	0.004784948
103	Lr	Lawrencium	256.0986	76.77631149	0.003904752
105	Ha	Hahnium	261	78.245712	0.003831423
74	W	Tungsten	183.85	55.1167592	0.005439225
75	Re	Rhenium	186.2	55.8212704	0.005370577
106	Sg	Seaborgium	263	78.845296	0.003802287
72	Hf	Hafnium	178.49	53.50987408	0.005602563
73	Ta	Tantalum	180.95	54.2473624	0.005526397
70	Yb	Ytterbium	173.04	51.87600768	0.005779019
85	At	Astatine	209.987	62.9524227	0.004762207
		Atomic Bndry	208.875	62.61914969	0.004787552
71	Lu	Lutetium	174.97	52.45460624	0.005715274
66	Dy	Dysprosium	162.5	48.71627444	0.006153846
67	Ho	Holmium	164.9	49.4357008	0.006064291
68	Er	Erbium	167.26	50.14320992	0.005978725
64	Gd	Gadolinium	157.2	47.1273024	0.006361333
52	Te	Tellurium	127.6	38.2534592	0.007837003
56	Ba	Barium	137.34	41.17343328	0.007281211
111	Uuu	Unununium	272	81.543424	0.003676476
107	Ns	Neilsbohrium	262	78.545504	0.0038168
69	Tm	Thulium	168.934	50.64506173	0.005919481
110	Uun	Ununnilium	269	80.644048	0.003717478
65	Tb	Terbium	158.9	47.6369488	0.006293276
108	Hs	Hassium	264	79.145088	0.003787885
109	Mt	Meitnerium	266	79.744672	0.003759404
57	La	Lanthanum	138.9	41.6411088	0.007199435
54	Xe	Xenon	131.3	39.3626896	0.007616158
62	Sm	Samarium	150.35	45.0737272	0.006651157
55	Cs	Cesium	132.91	39.84541561	0.007523888
58	Ce	Cerium	140.1	42.00092338	0.007137759
63	Eu	Europium	151.96	45.55639232	0.006580689
60	Nd	Neodymium	144.2	43.2300064	0.006934823
53	I	Iodine	126.9	38.0436048	0.007880233
59	Pr	Praseodymium	140.9	42.2406928	0.007097243
51	Sb	Antimony	121.75	36.499676	0.008213565
61	Pm	Promethium	144.9128	43.44369814	0.006900712
50	Sn	Tin	118.69	35.58231248	0.008425323

49	In	Indium	114.82	34.42211744	0.008709297
48	Cd	Cadmium	112.4	33.6966208	0.008896811
36	Kr	Krypton	83.8	25.1225696	0.011933192
34	Se	Selenium	78.96	23.67157632	0.01266466
46	Pd	Palladium	106.4	31.8978688	0.009398511
3	Li	Lithium	6.939	2.080256688	0.144113205
47	Ag	Silver	108.7	32.5873904	0.009199646
37	Rb	Rubidium	85.47	25.62322224	0.01170003
38	Sr	Strontium	87.62	26.26777504	0.011412937
44	Ru	Ruthenium	101.1	30.3089712	0.009891212
45	Rh	Rhodium	102.91	30.85159472	0.009717243
42	Mo	Molybdenum	95.94	28.76204448	0.010423197
35	Br	Bromine	79.909	23.95607893	0.012514254
40	Zr	Zirconium	91.22	27.34702624	0.010962525
39	Y	Yttrium	88.91	26.65450672	0.011247346
33	As	Arsenic	74.92	22.46041664	0.013347591
32	Ge	Germanium	72.59	21.76190128	0.013776023
41	Nb	Niobium	92.91	27.85367472	0.010763121
43	Tc	Technetium	96.9062	29.05170351	0.010319273
4	Be	Beryllium	9.0122	2.701785462	0.110960867
31	Ga	Gallium	69.72	20.90149824	0.014343109
23	V	Vanadium	50.94	15.27140448	0.019630968
25	Mn	Manganese	54.93805	16.46998789	0.018202348
29	Cu	Copper	63.54	19.04878368	0.015738142
27	Co	Cobalt	58.9332	17.66770189	0.01696839
30	Zn	Zinc	65.37	19.59740304	0.01529756
22	Ti	Titanium	47.9	14.36005874	0.020876827
18	Kr	Potassium	39.102	11.72246678	0.025574179
24	Cr	Chromium	51.996	15.58798483	0.019232278
5	B	Boron	10.811	3.241051312	0.092498523
26	Fe	Iron	55.85	16.74340878	0.017905103
21	Sc	Scandium	44.956	13.47744915	0.022244006
9	F	Fluorine	18.9984	5.695568333	0.052636092
19	Ar	Argon	39.948	11.97609082	0.025032581
28	Ni	Nickel	58.693	17.59569186	0.017037833
11	Na	Sodium	22.9898	6.892158122	0.043497618
17	Cl	Chlorine	35.453	10.62852578	0.028206401

13	Al	Aluminum	26.9815	8.088837848	0.037062488
15	P	Phosphorus	30.984	9.288755328	0.032274772
12	Mg	Magnesium	24.312	7.288543104	0.041132014
10	Ne	Neon	20.183	6.050701936	0.049546724
14	Si	Silicon	28.086	8.419958112	0.035604982
16	S	Sulfur	32.064	9.612530688	0.031187672
20	Ca	Calcium	40.08	12.01566336	0.024950138
6	C	Carbon	12.0112	3.60086167	0.083255755
		Atomic Scale Standard		3.484923	0.086025562
2	He	Helium	4.0026	1.199947459	0.249837987
		Electron Compton \square		1.235748	0.242599995
7	N	Nitrogen	14.0067	4.199096606	0.071394513
8	O	Oxygen	15.9994	4.796492125	0.062502439
	?	?	9.6231687	2.884949	0.103916034
1	H	Hydrogen	1.00797	0.302181342	0.992094535
		Alpha Particles Free Electron Formation			0.49
Copyright ©1992-2003 j.N. Hodges					

The Tamashii Frequency Chart

Important note: In the frequency separation of each Element, there is a bandwidth span of at least .5 exahertz. This means that every Particle, existing in a $\pm .25$ exahertz span from a specific Element, will exhibit the properties of that Element.

Example: Every Particle, from 3.96 – 4.45 EHz, will be a Particle having Nitrogen properties. The number of Particles that could exist in this bandwidth, at any one time – at any location, could number over 50 quadrillion.

Particles, whose frequencies fall within an Element’s frequency bandwidth, but exhibit slightly different mass characteristics from the primary Element, are known as Isotopes: From Greek, meaning Same Place (in the same place, within an element’s bandwidth, in the periodic table, but exhibiting different masses).

All of these Particles, are identified, by individual Frequency Numbers

There are two categories of Quantum conditions:

Fermions are electrons, neutrons, protons, leptons, and quarks
Bosons are Gluons, which mediate the strong nuclear force, and Photons, which mediates electromagnetism.

I shall take you now into the world of Quantum Physics and its realm of wondrous mechanisms, structures and events that border on the edge of human consciousness.

What is Quantum Physics all about?

It began as the science of Prediction. Specifically, the prediction of where a single particle will be at any point in time.

In Science and Physics, Reality is when something actually works. Everything, up to that point, is speculation and someone's dream and determination to prove it is real.

If a Particle (or any other elusive subject) exists, the probability of finding it, are positive.

Unfortunately, it was impossible to predict *both* the Position of a particle and the Time it will get there, together. We could look for one condition and observe the reaction, which should lead to the record of the other. As we were unable to capture one of these little guys, we could only guess where it would be and try to obtain information on what they actually were and why they existed in any moment in time. (Like looking for Bigfoot, with only footprints to tell us everything about it).

Here is a little analogy.

Imagine (good word), your friend drops a golf ball off the top of a 100-story building. You are sitting in a room on the 30th floor with a camera. Your job is to get a picture of the golf ball, centered in your window, as it passes. The calculations (a lot of guessing) involved, and the resulting picture, is what Quantum Physics is all about. Only on a very small scale. The golf balls, in this science, are 1 billion times smaller and are traveling at the speed of light.

Everything said, up to now, was to get you ready for a whole new way of thinking about the way our Universe is operating, for it indeed runs on only one basic Particle. Of course, there are countless numbers of these particles, but the rate at which they oscillate (Frequency) determine how they stick together and produce everything in the Universe.



Bells and Whistles

Three bells and a hammer. The beginning of a three note musical composition? What about three bells and a stick of wood? Or, three bells and a banana?



Figure 6

All three bells will individually emit a specific note (resonance) when struck by another object.

The musical note A: 440Hz
 940nm: 319,140.94 GHz (319 THz)
 Silicon: 29.98 THz (10 mm)
 Carbon: 302.181 THz (992 nm)
 88 key Piano Frequency Range: 27.5 Hz (cps) to 4186 Hz

But, what happens when one *bell* strikes another?



Figure 7

Beat and Superposition.

If the two tones are similar, the "beat frequency" is lower than the combined tones. As the tones get closer together, the beat tone begins to fade. But, when the two tones become more different, the "beat frequency" becomes higher. Eventually the beat frequency becomes so high that it sounds like a third tone. Well, actually... it *is* another tone.

This is what happens when two Particles 'strike' each other.

For simple demonstration purposes, I will assign the frequency of:

Hydrogen (0.302181342 EHz) to Bell #1
 Tin (35.58231248 EHz) to Bell #2
 Uranium (71.35948976 EHz) to Bell.#3

Striking the Bell #1 with Bell #2, will result in a Virtual attraction of Nickel (Ni 17.595)

Striking the Bell #2 with the Bell #3, will result in a Virtual attraction of Hafnium (Hf 53.509)

However, striking the Bell #1 with Bell #3, will result in a Virtual attraction of Tin (Sn 35.830)

I will be referring to a Frequency Emitter Array, throughout this book. This array will consist of three specific elements:

Bismuth: .0047851nm

Yttrium: .0112473nm

Lithium: .1441132nm

In the Light Spectrum, there are three primary colors. Red, Blue and Green. By combining these colors, in various proportions and hues, 16 million colors can be produced. Think of the three elements above as our three primary colors of Elemental Frequency reproduction.

"We are made of the Stuff of Stars."

-Carl Sagan

Elementary Particles

"Don't call me an Electron!"

The Universe consists of only one basic type of Elementary Particle. It has no form, and maintains one specific area of influence. They have always been and will always *be*. The best we can come up with is that these particles are pure energy in its pre-level form. They resonate at millions of different frequencies and each one, at any moment in time, performs a specific function in the operation of the Universe.

In quantum mechanics nature is described with waves, known as the wavefunction (ψ). The wavefunction is the probability of finding a particle in an exact position and at the exact time.

Such as: If the particle exists, it must be somewhere and what moment in time does it reside in?

These are not discrete particles whose motion and dynamics can be described with the deterministic equations of Newtonian physics.

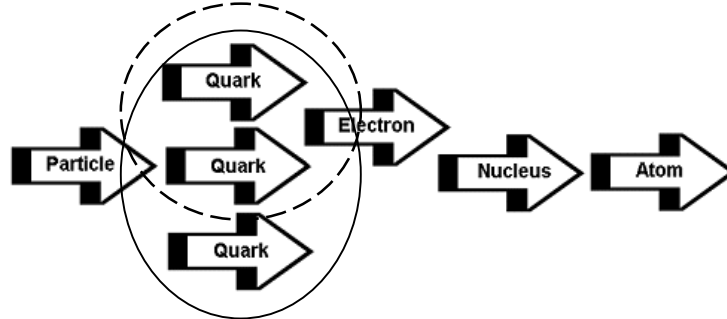

Figure 8

The above sequence is illustrating 'one' frequency, on its way DOWN, to form an Element of that specific frequency. In present-day technology terms of the One-Second Universe, the process leads to the formation of Electrons, Atoms and Molecules. 'The Tamashii Model' BEGINS at this level, and travels UP.

Particles form into a Quark.

Two Quarks form into a single Electron.

Three Quarks (an Electron attracting a Free Electron) form into the Nucleus of an Atom.

Atoms are combined into Molecules.



Figure 9

The three fuzzy spots, above, are Elementary Particles. Each one, in actual energy size, is only $\sim 1.616^{-35}$ centimeter across, until they collide with any dissimilar frequency bandwidth Particle mass, then they 'grow' (absorption/emission) to 2.817^{-15} cm. This is the *size* of an Electron. However, IT IS NOT AN ELECTRON.

In Fig. 10, a single Particle is represented, In 10^{-27} of a second, the Particle will grow (absorb) to fill the entire Electron Envelope (2.817^{-15} cm) and then return (emission) to its original energy size ($\sim 1.616^{-35}$ cm).

Absorption begins by a dissimilar frequency bandwidth particle mass making physical contact with the Particle. At this encounter, both of the colliding energy Speck's negative perimeters will repulse each other. The force of the repulsion will be equal the speed at which the dissimilar Particle mass' (-) negative perimeter entered the envelope.

(Can anything accelerate from 0 to 186,000 miles per second in a quadrillionth of a second?)

If the impacted Particle is a Free Agent, and in a Vacuum, it would maintain the repulsion speed, until encountering another dissimilar frequency bandwidth Particle mass.

Everything in the universe is constructed from these tiny wisps of energy, all maintaining their own 'negative repulsion' spacing from each other. This 'particle soup' forms the 'sea' that everything in the Universe floats within.

A single Particle exists by oscillating within a specific frequency bandwidth, pulling -negative (less positive) energy from its outer perimeter, into a more concentrated + positive center.

I will be referring to an entity, I call, a Free Agent. There are two types of Free Agents:

Free-Particles/Quarks (not pulled into a same-frequency bandwidth grouping)

Free-Electrons (not part of a same-frequency bandwidth Atom) populate every available portion of space, not occupied by Atoms.

When two of these Free Agents, within the same frequency bandwidth, begin to attract each other, they are able to join (creating a gravitational increase of 2x everything around them) or even pass through each other, without any disruption of their states. However, if either of them come in contact (accidentally or artificially forced) with a particle grouping or Electron mass, oscillating within another Element's frequency bandwidth (they cannot see each other in their own time frames), all parties will exhibit cross-frequency modulation, creating a third 'BEAT' and a fourth 'Superposition' (harmonic) frequency, also known as a Photon Event.

The following section illustrates the various stages of elemental development, displaying particle stages according to their organization and how they interact with one another.

(The following graphics are for illustrative purposes.)

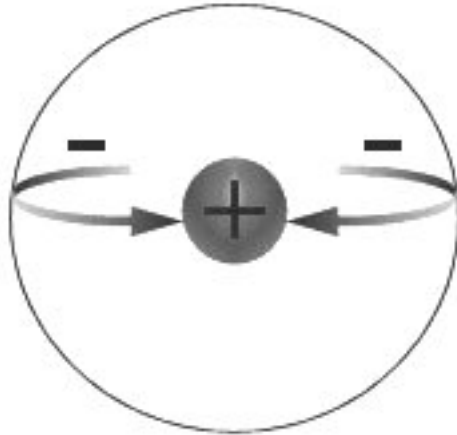

Fig. 10 An Elementary Particle Property

A single particle does not rotate or spin, but pulsates. The action being a continuous agitation, from the perimeter to the center. The center having a more positive potential (condensed) than the surrounding negative cloud or 'fuzz' (- negative always travels to + positive, and the positive side does not radiate, but absorbs).

Because the negative side is dominant (always in flux and always the portion that interacts with surrounding particles) this particle stage is considered negative.

Ever try to shake hands with someone else in a passing car? (Moving in the same direction, of course.) You cannot do it. At best, you will just get a 'high five' at 50 miles an hour. Both cars need to be at a relative speed to each other. This is how a same frequency bandwidth Mass of particles bonds.

When the Universe began, whether caused by a Big Bang or just 'happened' (It doesn't really matter at the moment.),

identically vibrating particles were present, traveling in every direction, at different speeds. . . filling up the void. (Nothing is always before Something). The key here is that there is only one source for what is around us and it is in countless numbers. The rate, at which a single unit is oscillating, at any one moment in time, determines how it reacts on its neighbor.

In an individual unit of a mass' voyage, it will eventually meet up with another having the same resonance and going in the same direction. Resulting in a handshake.

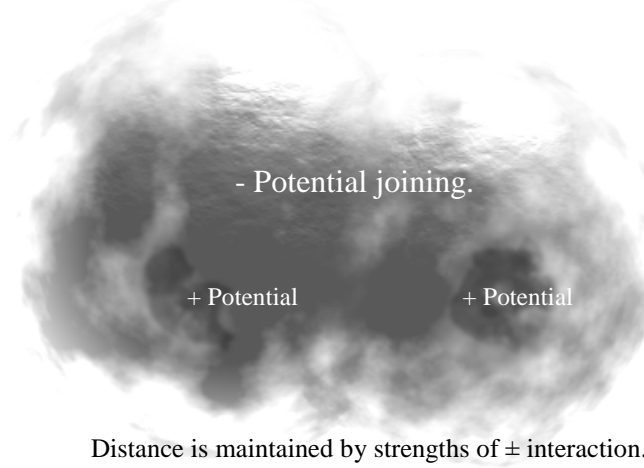

Distance is maintained by strengths of \pm interaction.

Figure 11 A like-Particle Handshake

Two bandwidth frequency-matched units will join (bond) at the point of equilibrium, due to the charges being generated. And because they pulsating, each will have polarized charges emanating at each potential. Due to this potential property, one's north (+) pole will be inside of the other's south (-) pole.

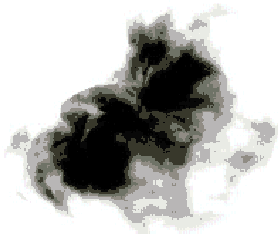

Fig. 12 A single elementary particle (Virtual Photon).

However, when reactions of the positive side influence observations, such as attracting like-Particles, it is called a Boson and begins of the formation of a Quark. The particle's characteristic depends on what phase you are looking at . . . 'at the time'.

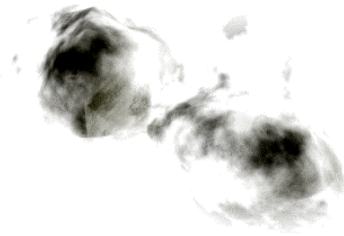

Fig. 13 Two Particles bonding (Real Photon).

When two particles bond, it is due to attraction based on their similar frequency bandwidth. It is called 'casual bonding' and is *the first appearance of a gravitational force*. However, when two like-Particles bond, they will cancel out each other's observable frequency, becoming invisible to observation, until coming in contact with a particle of a dissimilar frequency bandwidth. (Most observers were confused to this 'blinking' in and out of existence). But, the presence of the matched pair will be very evident, as they will attract other individual like-Particles.

Only like-Particles may bond, for, due to their time-based existence, within their elemental bandwidths, they can only 'see'

each other (± 5 EHz). However, any incidental contact with a particle mass, of another element's frequency bandwidth, will result in a Photon Event (absorption and emission).



Fig. 14 Three identical frequency bandwidth Particles joining (Virtual Graviton).

Once linked with an additional like-Particle (same frequency bandwidth particle), the three matched particles become a Virtual Graviton (I didn't come up with the names). This combination is unable to pulsate in a workable phasing, thus begins a type of spin or 'chasing' of one another (each negative being shared by the proceeding one's positive). Transference into an unstoppable shared cloud of negative energy, it is at this point that Electromagnetic Radiation effects can be detected and the packet enters our 'one-second universe'. It is the smallest form of Mass in the Universe. This grouping can only travel transversally, due to the internal 'three-legged race'.

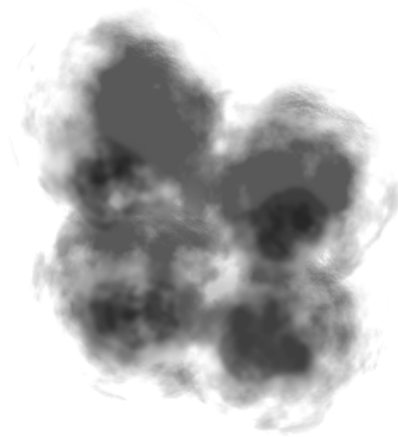

Fig. 15 A four particle grouping (Real Graviton).

When a fourth like-particle enters the configuration (Real Graviton), there are two - and two + potentials balancing the grouping. This is the first strong-bond device. The particles are joined at their balanced points, which is actually deep inside the +potential center of one another, thus creating a 'neutral' profile. Because the particles are linked at all points, including the center, it will never collapse 'into' itself.

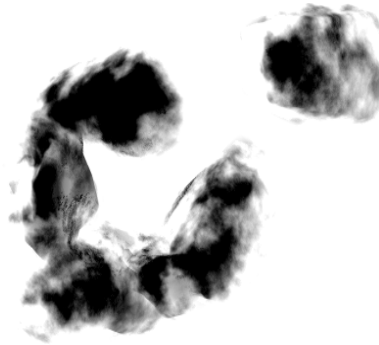

Fig. 16 A five like-Particle string (Gluon), attracting a sixth.

When five like-Particles are grouped, into a string, there will be either 3 positive and 2 negative 'faces' or 3 negative and 2 positive 'faces' at each observable plane, unless inspected faster than the particle string's frequency. This un-balance creates an effect, resembling a magnetic hand, which captures a passing like-Particle. It is known as a Gluon.

When a sixth like-Particle is attracted to the Gluon, observations show a balanced unit, consisting of one large positive charge and a matched negative (W^+ , W^-), along with a mass equaling $\sim 80 - 90\text{GeV}$.

When a Particle Cluster matures, containing all 6 types of Elementary formations, it becomes a Quark, with each component particle resonating within a very narrow bandwidth of the same elementary frequency.

“Manipulation of the elemental frequencies is the closest we can come to playing with Angels.” - *Hodges - Vitoria, Spain Lecture -1989*

Quarks

A Quark is nothing more than the interactions of 6 similar bandwidth frequency Bosons (Elementary Particle groupings), in a cluster. The interference, beat and superposition reactions, to one another, create 6 'flavors', which dictate the properties and characteristics of the Quarks. These states are: *Up, Down, Strange, Charm, Bottom and Top*.

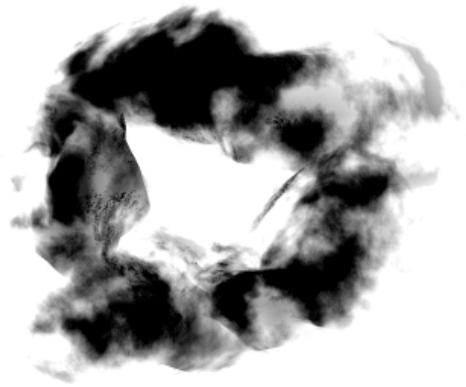

Figure 17 A Single Quark

A size, or Timeframe, cannot be applied to a single Quark..

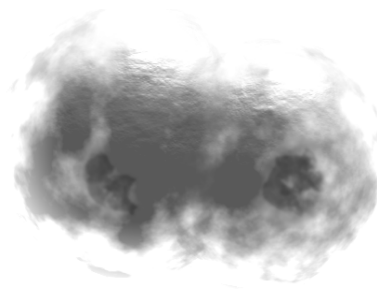

Figure 18 Two Quarks - Free Electron

Two Quarks, of the same frequency bandwidth, bond, forming a Free Electron. This formation is where the future of technology resides.

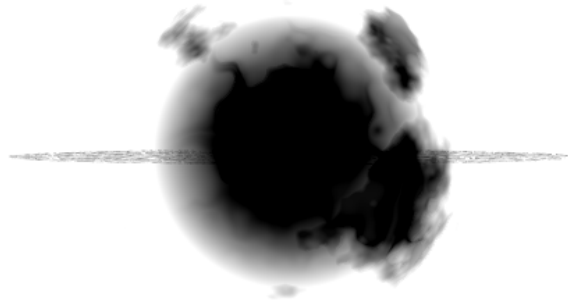

Figure 19 Three Quarks - Electron Nucleus

Three Quarks, of the same frequency bandwidth, will bond in a Virtual Graviton configuration to form an Electron Nucleus. This energy pack will continue attracting like-Particles and Free Agent Quarks, from its stronger positive (+) interior.

The radius of an Electron is less than 10^{-18} m.

Think of an atom - say hydrogen, with a single proton nucleus. The electron cloud encompasses the nucleus, instead of a neat circular orbit, as was imagined, and appears at all points almost simultaneously. It behaves like a wave.

There are an equal number of protons and electrons in an atom. (i.e. Helium's atomic number is $2\text{He} = 2$ protons and 2 electrons). However, even though the numbers are equal, the energy masses are not. The proton's energy mass is 1836.1526665 times larger than a single electron. (1 electron=3.5 energy mass).

What about the positron? The free positron is also a bullet; it has the same mass as the electron and carries an equal and opposite amount of charge. Bring a positron and an electron together and they will annihilate to give ENERGY!

When it jumped from one of these orbits (Photon Event) to another the atom emitted or absorbed light.

When an Electron bonds with another, of its own frequency bandwidth, it becomes the Nucleus of an Atom.

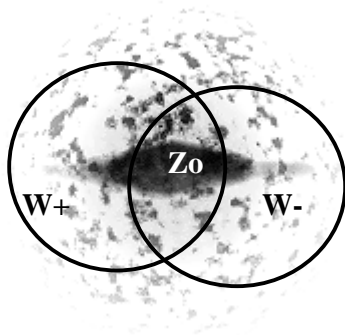

Fig. 20 The single nucleus of a Hydrogen Atom ($W+$, $W-$, Zo).

This is a model of a single Nucleus within a Hydrogen Atom. This grouping will still exhibit their familiar individual traits, all of energy packets pulsating at a common frequency bandwidth, but not at the same time.

The identity of an element is determined by the number of Protons/Neutrons in the Nucleus. This number equals the atomic number.

Atoms are neutral. The number of positively charged protons are canceled out by an equal number of negatively charged electron.

Example: A Helium atom has 2 protons and 2 neutrons in the Nucleus. There are 2 electrons associated with this atom, matching the number of protons, canceling out any charge value. This leaves only the neutrons (neutral charge).

However, because half of them are 'out-of-phase' with the other half, the electron's nucleus becomes (as in the joining of two particles) 'invisible' to observation.

This is the root of the Neutron/Proton myth. When we are able to observe, in the EHz range, we will see the reality of the grouping.

This energy pack will continue attracting like-Particles from it's stronger positive (+) side, either adding it to the mass or pass them through it's center to another like-electron nucleus in close proximity.

An enormous amount of energy is produced by this action, for as additional like-Particles pass *through* this massive electromagnetic combined field, they exert in all directions, waves of attraction, repulsion and Time stamps.

Quarks produce either, or both, of the two forces in the Universe:

Gravitational (Formation of Single Quark - elementary particle attraction)

Electromagnetic (Two Quarks in flux).

Each Electron has enough gravity and electrical energy to begin the formation of an atom. A resonating mass of same frequency bandwidth particles, held together by Time.

Notice the small ring of particles, at the equilibrium point of the electron? Interesting how this effect keeps cropping up, as is evident in atoms, planets, solar systems and galaxies.

How weak is gravity? An exchange of positive (+) protons within an atom will result in an electrical charge predominate over gravitational attraction (- elementary particles) by a factor of 10^{31} power.

And it all begins in the sea of particles.

Why have we been stuck in this physical world, at the electron-level, for so long? We just never discovered how to reset our clocks.

Chapter Three

GRAVITY AND LIGHT

Statement: Where there is light, there is Gravity.

Explanation: A Photon Event will only occur when a Particle contacts a mass of a dissimilar frequency. Where there is mass, there is Gravity.

In the early years of the 20th Century, a Physicist named W.H. Bragg wrote: "Physicists use the Wave theory on Mondays, Wednesdays and Fridays, and the Particle theory on Tuesdays, Thursdays and Saturdays."

A single Particle can never exist in more than one place at once, and to travel to a different place in space, a particle must move to it under the laws of kinematics, acceleration and velocity.

A wave can propagate until it exists in all locations and at all times. In addition, electrons can display diffraction, an obvious wave property.

In 1801, an English physicist named Thomas Young, conducted an experiment to infer the wave-like properties of light. He wanted to observe the interactions of two light waves met. He used sunlight as his light source.

Carrying out the Young double-slit experiment, today, with electron beams, produces the same results. (Fig 20, below)

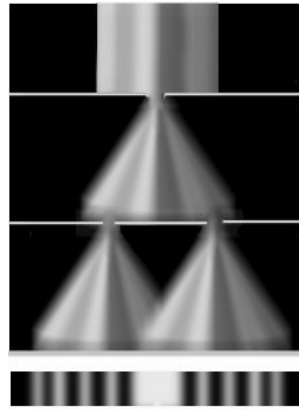

Observed rear screen.

Figure 20

In Young's original experiment, sunlight passes first through a single slit, and then through two thin vertical slits in otherwise solid barriers, and is then viewed on a rear screen.

The observed pattern, on the lower target, shows the results.

These same results appear whether the experiment uses Particles, Quarks, electrons or Atoms.

However, electrons can display diffraction, an obvious wave property. This is also shown by carrying out Young's Double-slit experiment with electron beams.

When either slit is covered, a single peak is observed on the screen from the light passing through the other slit.

But when both slits are open, instead of the sum of these two singular peaks, that would be expected if light were made of particles, a pattern of light and dark fringes is observed.

This pattern of fringes was best explained as the interference of the light waves as they recombined after passing through the

slits, much as waves in water recombine to create peaks and swells

Particles are individual, three-dimensional discrete packets of concentrated energy, confined to a finite space, at a specific location and modulating within an identifiable frequency bandwidth. When these Particles form into groupings of their own frequency bandwidths, they establish Quarks, eventually combining into matter. In this concentrated state, they can never exist in more than one location at any moment in time.

Electrons behave according to the laws of acceleration and kinematics and respond to collisions and interactions of other Electrons. (They do not break, but do get upset when hit.)

These laws, known as Newtonian Mechanics, were first published by Sir Isaac Newton, in his work: *Philosophiae Naturalis Principia Mathematica*. (1687)

What was *not* published, is that a Particle blinks into existence when two Quarks, resonating within the same frequency bandwidth, join.

Particles do not behave according to Newtonian Laws.

Atoms have nuclei containing protons and neutrons, and have electrons in the surrounding space. The nucleus is only 1/100,000th the diameter of the atom. And a billion atoms in a row would make a line only a few centimeters long.

All Particles can be considered to be waves. Also, certain waves can be considered as Particles. And in physics one of the most important waves is light.

Superposition is the process whereby two waves cross each others paths. The superposition principle states that: The

resultant instantaneous deformation is the sum of Individual instantaneous deformations.

The waves do not interact, they are in a sense invisible to each other, but observing the behaviour of particular areas where the waves meet, certain phenomena can be seen.

Consider two plane waves of similar frequency and amplitude traveling towards each other. When they meet their resultant amplitude at any point will be the amplitude of the first, at that point, plus the amplitude of the second, at the same point.

If the amplitude of the first wave is positive and the amplitude of the second wave is negative then the total amplitude will tend towards a neutral point where amplitude is zero. If the first wave's amplitude is the exact opposite of the second wave, then the total amplitude will indeed be zero. This is known as destructive interference.

"An apple fell on Newton's head and he thinks he's Einstein."

Gravity

I will begin this portion of my presentation, by standing on this very tall stepladder, up here on the stage, and dropping two ping-pong balls and a single tennis ball, at the same time. The reason is to duplicate an experiment by Galileo.

Down they go, all falling at the same rate, until they hit the floor *together*. They all bounce a few times, with the two ping-pong balls rolling around and finally coming to rest under the podium (lost forever).

The Orangutan, who has been sitting in the front row and throwing orange peelings at me, jumps to the stage and shoves the Tennis Ball in his mouth. Not quite the same results as the famous Galileo demonstration, but mine was funnier.

Seriously, what I wanted to show was that what we are taught in school, about Galileo's demonstration, was basically correct. His observation that objects, of any size and number, dropped at the same moment, will fall to the ground at the same rate.

We were never taught the Why.

The Truth is, we must get smaller in our explanation to reveal the Why of this demonstration. Down to the Particle level of each item. And we must envision things moving faster. Down to the bazillion moments that exist - *within a second*.

What was really happening, when the balls were dropped, was that every *single* one of the billions of Particles, that made up the mass of *each* ball, was trying to get 'down' to a higher concentration of particles, of their own kind.

Even when I tape all three balls together, the bunch will drop at the same rate as the lightest, single ball. It is each Particle for themselves.

The highest concentration, within each ball's 'sight' (time frame), was only in one spot, the entire surface of the Earth, *below* the drop-point. ¹ And because *every* Particle is the same size, each traveled 'down' at the same speed. I call it Gravity Pull. (Fig.21)

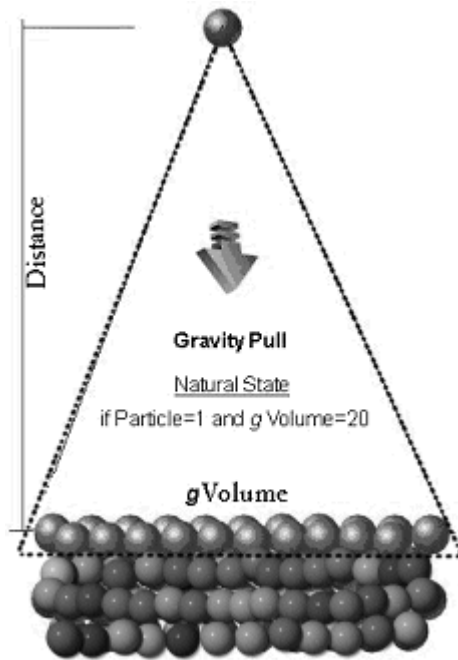

Fig. 21 - Gravity Pull

When the balls hit the Stage, they could not travel any further 'down' to the highest concentration (mass), which is deeper in the Earth, so they just rested on the surface (under the Podium, etc.).

This attraction is known as Gravity (g).

And the measurement we use to see how far away a smaller concentration of Particles (ball) are resting, from a huge concentration of Particles (Earth), is called Weight (Distance).

I mentioned earlier, about each Particle's 'sight'. This is an important factor in our 'falling ball' demonstration. It's about Time. *

*In the author's opinion, there may be many explanations of the effect of gravity and The Tamashii Model will be confined to that opinion, not because of any arbitrary attitude or because it is the author's own theory, but rather, all points can be experimentally verified and all conditions can be met and checked. But, sadly, all findings are limited by present day 'Fred Flintstone' testing technologies. Many forms of Gravity Control may be discovered, this is only one approach, for a specific future application.

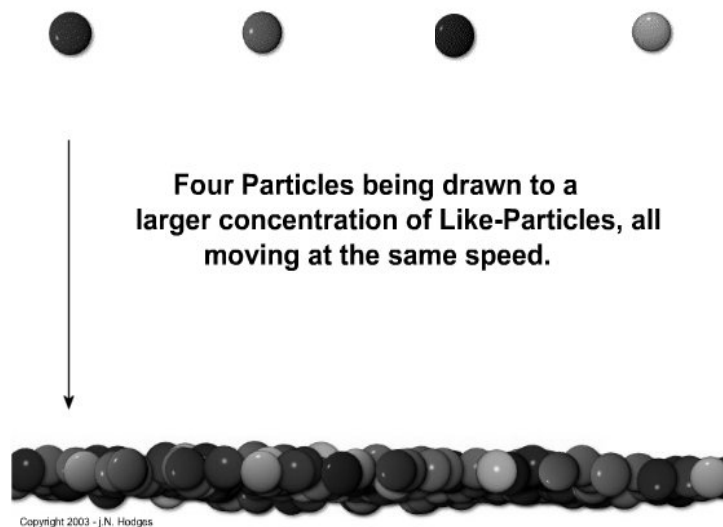

If the distance, from the Four Particles to the Particle Mass, is great, each of the independent particles may begin to attract each other, on the way 'down'. This bonding will not affect the speed or rate of attraction.

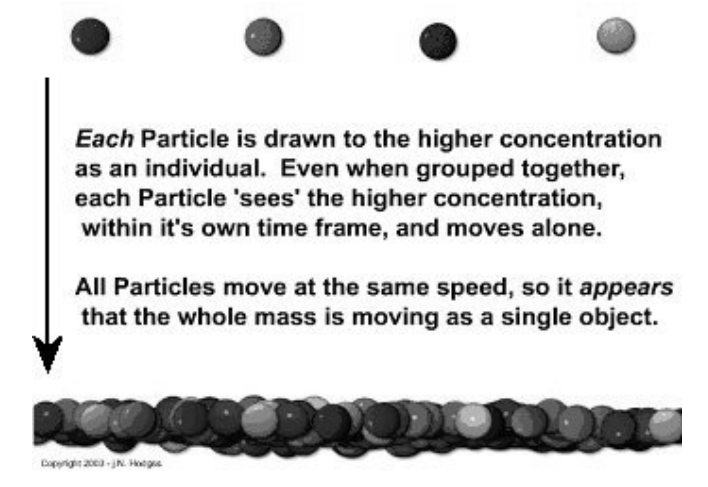
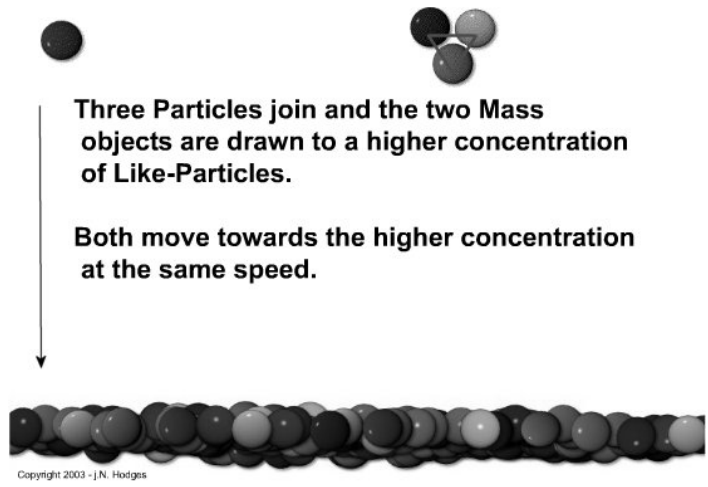

The 'area of influence', particle-to-mass relationships, are relative to two vector conditions. One vector is depicted below, as the overall path of all free-agent particles, in relation to the mass. This is like a funnel, with all of the particles being poured

into a central container of a higher potential than each independent Particle.

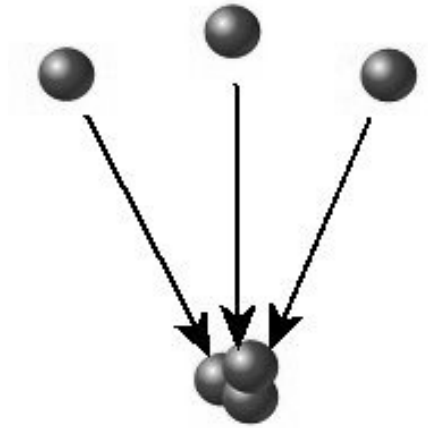

Fig 22

The other is the relationship of the particle-mass, from the Particle's point-of-view.



Fig 23

This is where the gravity bond can be manipulated, as it is feasible to modify the single particle to repel the larger mass.

What we need to define is the individual particle's properties, which may be *amplified* to counteract gravity. I will approach this feat on two levels, both of which can be manipulated. One is Pull - The other Push.

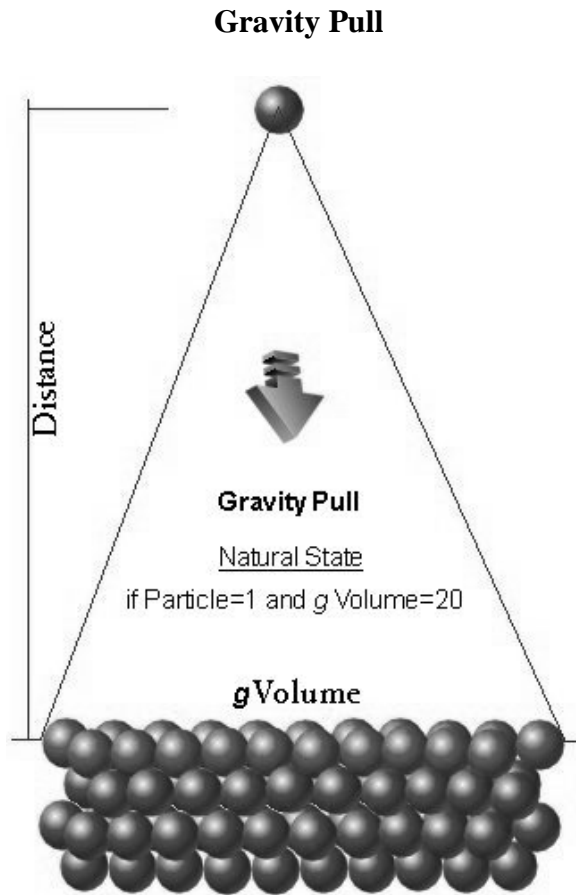

Fig. 24

A single Particle being pulled down, to a grouping of like-Particles. The ratio, in this graphic, is 1:20. The Particle's Vector and distance, from the surface of the mass, allows a 20

Particle grouping to supply enough attraction to draw the single Particle down, from its initial distance.

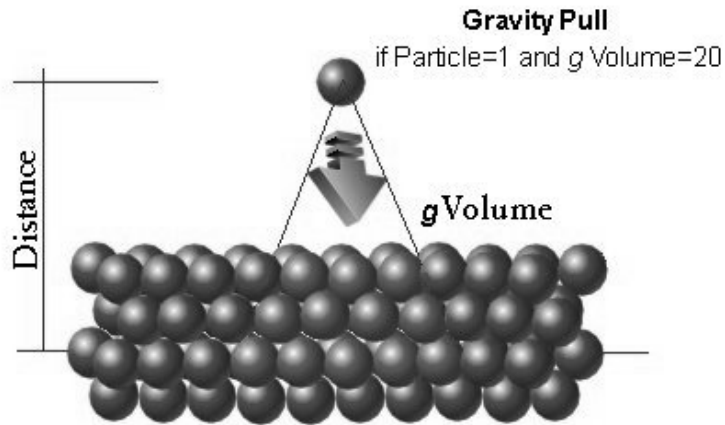

Fig. 25

As the Particle is drawn nearer to the mass (Earth), the ratio remains the same 1:20, however the Vector now draws from *inside* the mass to maintain the ratio.

Note: This mass, in this graphic, only needs to be 4 layers thick to maintain the ratio. (1 layer = 2.817^{-15} cm)

Gravity Push

Particle has a minimum 21:20 mass ratio.

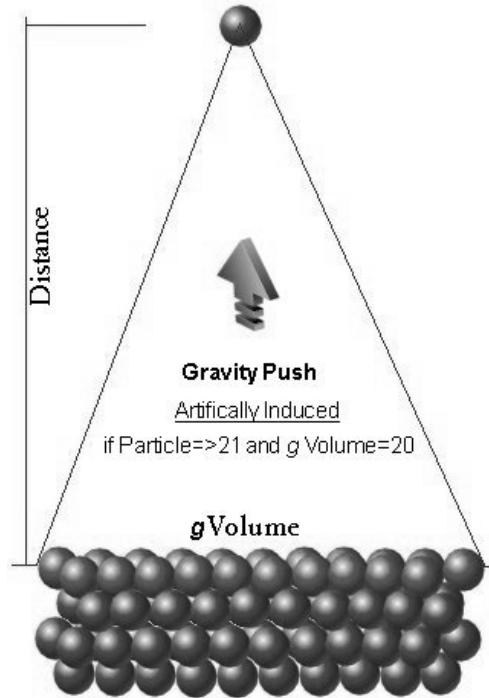

Fig. 26

A grouping of like-Particles rest upon the surface of a composite mass (Earth). The required percentage of like-Particles required to keep the Gravity bond, are lower than the artificially induced massive like-Particle (21:20). So, off it goes to find the proper percentage.

There are two ways to accomplish this feat:

One is to maintain the Vector and increase the 'volume' of the signal induction into the target Particle. (The higher the imbalance ratio, the faster the Particle moves away.)

The second is to narrow the Vector to change the ratio. This approach could result in an unstable 'flight', but could be controlled by utilizing triangular models.

These are two separate technology paths, but both require a Tamashii Engine.

Here is an important key to the future of Humanity's exploration . . .

The like-Particle grouping only has to 'Sound' massive!



Fig. 27 SNOW Gravity-Push Unit

The above illustration is a graphic depicting the Snow Gravity Push device, which has been under development since 1985.

The basic principle was explained, at the beginning of this chapter, which is to modify the frequency of spherical lower housing to *appear* as too massive for the exchange of localized particles to accommodate.

The Snow unit is designed around the Tamashii Engine and Radiant Energy units to address both Push potentials, Vector and Volume.

Yes, Virginia, this could be a UFO engine. Actually, anything that needs to go UP, could use this device.

Specific Gravity

I have been referring to the 'size' of particles. This size is based on the Bohr radius of a Hydrogen atom ($5 \times 10^{-9} \text{m}$), and working our way down to Particles. However, particles behave as though they are waves packets, like little clouds of highly-charged, electrical, floating baby oil. The time/space they affect, which is around them, is where I am focusing this chapter.

The easiest way to demonstrate Waves and Particles, as well as, how the Universe eventually formed into multitude of Galaxies, is to mix up a big bowl of water and various oils.

As we slowly agitate the bowl, we can observe the wave action, causing a deformation of the surface. This agitation continues throughout the mixture.

As the mixture settles-----

In the next series of pictures, the first frame is showing the whole of the contents, existing as an entity everywhere in the bowl, at the same time and in every position (displacement). Each nodule, of every ingredient, is moving around every other ingredient nodule, but not mixing.

The second frame shows settling of the mixture, with lighter oils moving up and heavier oils and water down. A layer of

'medium' specific gravity oil is position in between the layers.

Bubbles of the middle oil are concentrating there, also.

The third frame captures the final separation of the mixture, at the omponent layers. If an oil is near the same specific gravity of another, but its volume is much less, it may form a bubble of itself, inside the gravity layer of the larger volume.

This is happening with the medium oil bubbles, which begin to 'attract' each other.

The elemental frequency bandwidth of the medium oils composition has attracted the two factions, into one.

The final grouping and specific gravity positioning of all of the oils and water.

This is exactly how the earth's atmosphere 'stacks up', as well as how the elements were formed and 'packed down'.

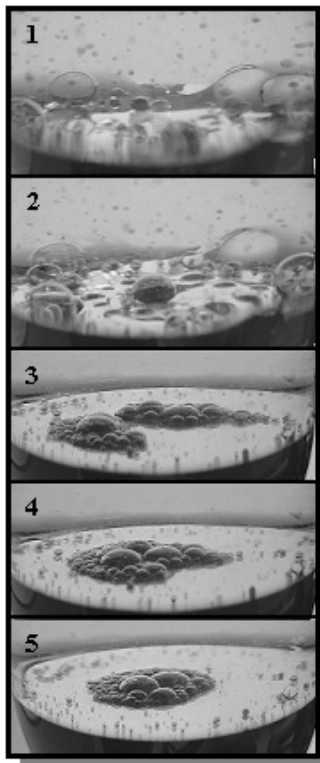

Element Configurations

What does the Atomic Number, in the Periodic Table, really mean?

Basically, how many Electrons, of a specific frequency bandwidth, can occupy an Electron Envelope, at any given moment.

We must look at our single Hydrogen Particle once again, and begin an illustrated climb up the Periodic Table.

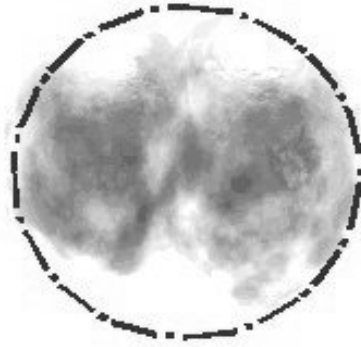

Fig. 28

A single Hydrogen Electron oscillates at 0.302181342 exahertz within the Hydrogen Atom (Fig. 28). This means that the single Hydrogen particle expands to 2.817^{-15} cm and contracts, back to its original energy size, one time, in 10^{-27} of a second.

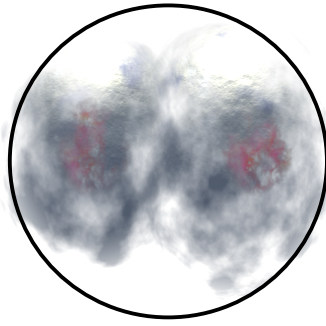

Fig. 29

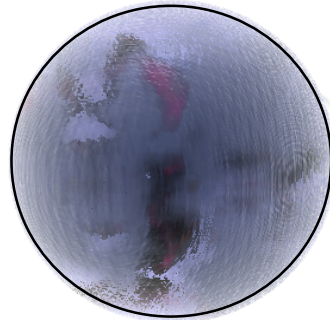

Fig. 30

A Helium Atom: 2 Electrons.

A Lead Atom: 82 Electrons

The energy size of every Particle is the same, but the physical configuration can adapt to any constraining condition.

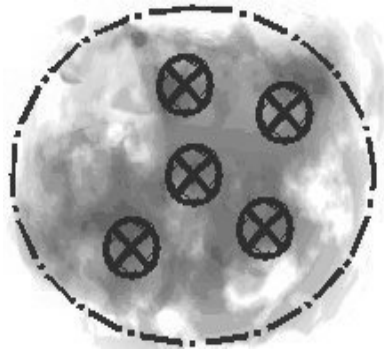

Fig. 31

In Fig. 31, there are 5 Electrons existing in the Atom (Boron). As all Particles are of the same Energy Size, and each are various stages of oscillation, I have indicated \oplus the position of each Quark/Electron's + (more concentrated) center.

Notice the space available for any Free Agent to pass through the Atom.

However, view the Atom of Lead. There is no space available for any Free Agents to enter. Neutrons are stable only while inside nuclei of atoms of elements, up to and including those of lead.

Lead is the densest Element, due to the 82 Electrons (the maximum number of Electrons that can occupy the 2.817^{-15} cm envelope of an Atom at the same time, based on an Electron's standard energy size).

The oscillating relativistic mass (coherent motion) of the electrons, in the Atom, creates extreme charge-density gradients in plasmas, which generate fields of gigavolts per centimeter, when stimulated.

And it just keeps growing, until over one million-million particles are bonded to form a complete Atom.

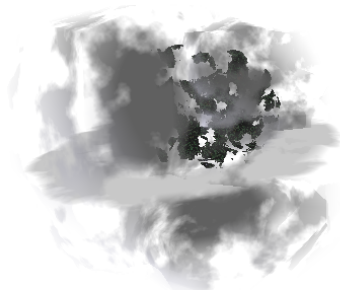

Fig. 32 A Hydrogen Atom

The Hydrogen atom (monatomic) is the first number in the periodic element evolution. It could also, be considered the last, if one views the periodic table as ascending. Because the elementary frequency bandwidth of Hydrogen is slow (the *single* atom's absorption width reaches the limits of atomic shell size (2.817^{-15} cm)) it can only maintain one electron grouping. It is impossible for it to grow any larger.

If a Hydrogen atom attracted an additional Electron Grouping, would that make it another element?

The answer is: No. There is no more room for another Electron Grouping (of the same frequency bandwidth) to enter the envelope. It would just move on to make an additional Hydrogen Atom. (*Unless a Bonding Element was present*).

When two, faster frequency Electron Groupings, loop and join, you have the next element in the periodic evolution: Helium. And it will be the same envelope size of the Hydrogen atom.

Every electron mass is of the same energy size. It is their individual speed, of outward oscillation, that determines how many can fit into the space of an atom, 2.817^{-15} cm, in the Quantum Time Period (QTP), at the same time.

A Hydrogen Electron oscillates so slow that in the QTP 10^{-27} of a second, it reaches the limits of the atom's envelope. There is no more room for another electron.

The illustrated atom, in Fig. 33, has two nuclei, and is referred to as the Alpha Particle, or Helium.



Fig. 33 A Helium Atom

This bonding mechanism will continue, until every one of the 88 basic elements (frequencies up to and including Uranium), in their 9 categories, are formed. The higher the frequency, the higher the atomic number and shorter the wavelength.

This can be referred to as, a spherical harmonic. It is a complex mathematical function of the Particle coordinates, within the Atom. Depicting the functions, and what portions of their Universe are affected by the actions, require four dimensions. Explaining them requires Human imagination and artistry.

1. #43 Technetium, #61 Promethium, #84 Polonium and #85 Astatine are artificially prepared.

Chapter Four

THE INTELLIGENT UNIVERSE

"According to the general theory of relativity, space without æther is unthinkable." - A. *Einstein*.

Every particle in existence vibrates within a specific Element's frequency bandwidth.

This is very important to remember, for without their individual oscillating patterns (frequency), every particle would be the same, and the Universe would be nothing more than a single cloud of (something)? However, the real point here is, EVERYTHING has a specific frequency 'fingerprint'.

In the early 1920's a group of physicists were in heated discussions over what composed the 'space' between electrons. For, in order for free-electrons to move around, they had to move around in 'something'. The area was to be known as the 'ether' or 'æther'.

The basic notion was that: A sea of really small squishy things (or something like them) fill every possible 'hole' between electrons, just like a glass bowl full of frog eggs. All pressing together in some areas, or just casually drifting in areas where nothing with a positive attraction, was present.

It is a sea of negatively charged particles . . . everywhere.

The interesting thing about this is: Where ever these particles 'bunch up' with others of their own 'frequency bandwidth', they

form specifically resonating stuff: like electrons and then atoms, whose density become a piece of individual matter that contribute to the make-up of our one-second world. One of the 88 known basic elements. 88 separate groups of individually matched frequencies. These resonating units construct everything, even you and me, as they continue to evolve into molecules. They all begin in this sea of Elementary Particles.

Everything is linked together by the negative to positive frequency attractions of these elementary particles. We all share the same sea of particles and the bubbles that surround each of these particles are in constant contact with its neighbor. The more particles in an area, the more Dense the mass becomes. As well as, an increase in Gravity pull.

If anyone approaches you with a theory of gravity and mentions that Magnets are the key, anywhere in the pitch, run away. And check, to be sure, that you still have your wallet.

Photon

Events

Normally, a Particle will not 'roam around', on its own. However, sitting comfortably, in a cozy envelope, without creating any emissions or doing any work, is not the way of the Universe. What is the driver, or pump, that initiates Particle participation? It is the resultant 'bump' that is delivered from a dissimilar Particle mass encounter.

It is like a rack of Billiard Balls, sitting quietly on a table, when suddenly, one of them grows to the size of a Basketball, pushing the others into each other.

Or, in other words, a Photon Event.

In the case of living cells, this 'pump' is known as Light.

The characteristic size of a photon effect emission is inversely related to its element frequency:

$$\alpha = c / f$$

where:

α = photon size

f = photon frequency

c = speed of light

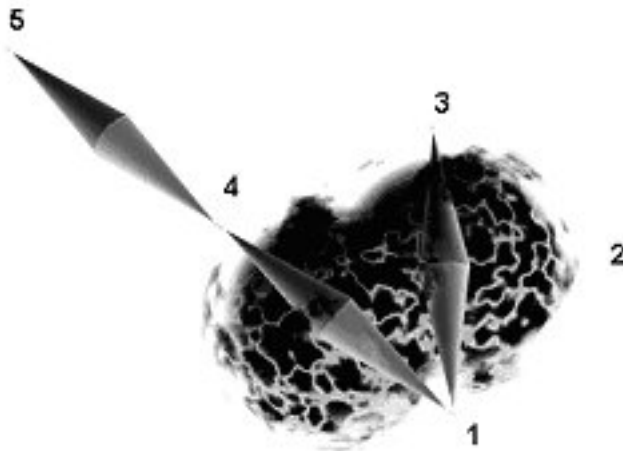

Fig 34

1. Two dislike-Particles make contact, initiating an absorption/emission event (photon). The energy size of each particle is 1.616^{-35} meter, at this moment. Like billiard balls, they move off in reactive angles.

2. The peak of the event, as the 'negative wake' expands to 2.8179^{-15} centimeters (the same diameter as an Electron). Observable frequency disruptions, of other bands, occur at this stage (5^{-28} second).

3. The end of the event. This occurrence required $1E^{-27}$ second to complete and occurred over a space of 2.817^{-15} centimeter (The restricting envelope of every particle). One particle is unable to make contact with another and becomes static.

4. This particle strikes another, of its own kind, and continues the action. Because the particle, that is being struck, is within the same frequency bandwidth, they 'phase' each other and no 'cross-frequency' beat oscillations will result. Both are invisible to any observation, at this moment, but still influence surrounding particle states. (i.e. A cloud of pure Hydrogen, in space, cannot be seen or detected by us, with our electron-level instruments, until it 'lights up' and 'gives-itself-away' by it's outer fuzz coming in contact with un-like particles, or the large negative activity around it affects surrounding matter. The easiest way for us to know it is there, is by the disturbance it causes on our lower-band, electron-level monitors. (The result of the Event is a lower frequency leftover.)

5. This particle is unable to make contact with another and becomes static. The action/reaction chain ends.

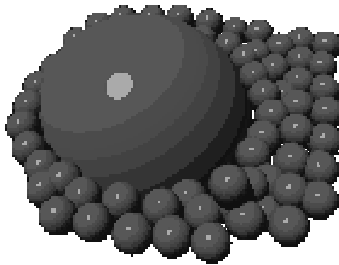
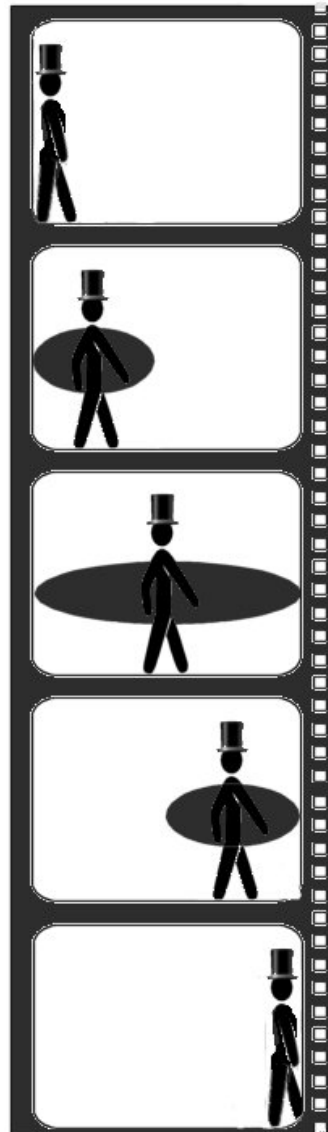

Fig. 35

A Particle reaching the Electron Envelope limit of 2.817^{-15} cm.

Fig. 36



Here is a visual scenario;

A Man stands, with his back against the left wall of a room he can cross in 10 steps.

As he steps forward, to the opposite wall, his body begins to swell at each step, with his back still touching the left wall.

By the time he reaches the Center of the room, his belly is touching the right wall he is walking towards, and his back is still touching the left wall he just left. (These 5 steps, to the Center of the room, will be called Absorption).

As he begins to walk the final 5 steps forward, his back leaves the left wall, but his belly stays in contact with right wall. His body starts shrinking back to its original shape, with each step.

He reaches the right wall of the room, in the same energy sized body, with which he began his trip. (These last five steps, from the Center of the room to the right wall, is called Emission).

This Man is our representation of an Elementary Particle, expanding to 2.817^{-15} cm, in 10^{-27} second, after making contact with a Particle within a different Element's frequency bandwidth.

Now, here are a couple things to think about.

The man was walking at the speed of light. But, his belly moved forward, and got to the right wall, before his Hat. How fast was his belly going? It appears that the effect of the man's movement, towards the right wall, was communicated 5 steps before his Hat arrived.

What if the right wall was actually another man, with the same capabilities? Would the first man begin the second man's expansion, as soon as his belly touched him? That would mean that the second man's belly would touch his right-side wall at the same time the first man's Hat reached the end of *his* trip. This is the basis of what I will discuss in Particle Communications .

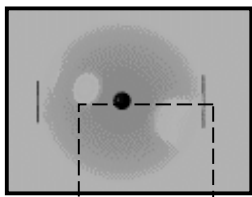

Fig 37 Particle at maximum Absorption (2.817^{-15} cm).

Below is a magnification of the outlined section above.

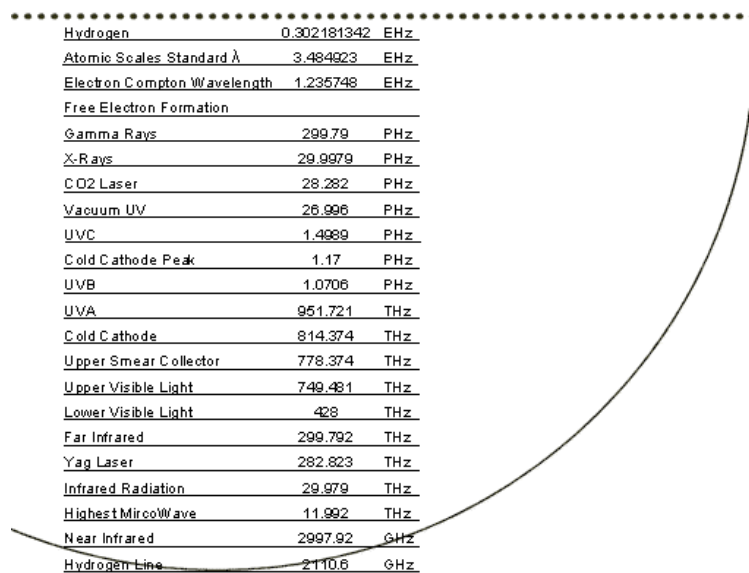

Fig. 38

As the absorption increases, the frequency envelope passes into, and though, the listed bandwidths and affects each.

The Official Tamashii Explanation of a Photon Event

Submitted to the U.S. Patent Office - Feb., 2002

An Elementary Particle is 'static' as long as its' specific oscillations, inward from all directions, are synchronized and undisturbed by outside influences. When a particle encounters a mass, within a dissimilar frequency bandwidth as shown in Fig 10, the resultant cross-modulation frequencies will induce perpendicular field effects on the spherical boundaries of the particle, from the point of mutual contact (200). The Particle field disruption will dissipate the energy bundle to a point of near absorption, absorbing any surrounding weaker fields. Upon reaching a mass that exhibits a stronger negative shell, to the positive core, the field will reform to electrical normalcy (201).

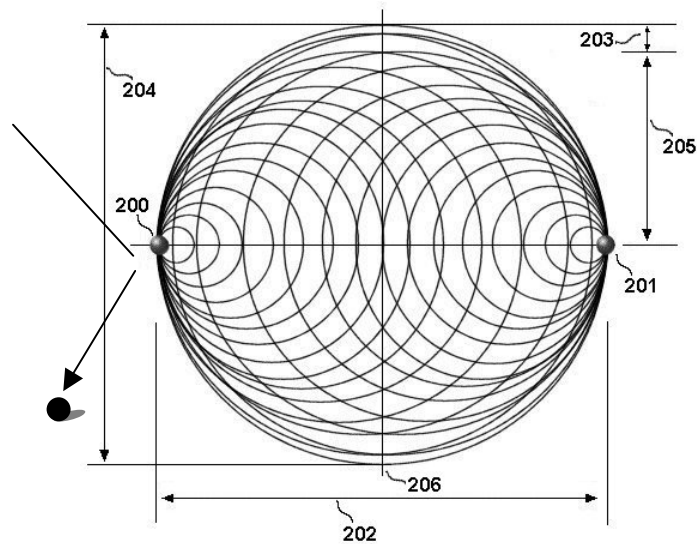

Fig. P Absorption/Emission of Photon Event

This absorption/emission affect, hereunder a Photon Event, may affect up to 100,000 dissimilar particles, within the

encountered mass' outer layer (204) in the localized area of 2.817×10^{-15} cm.

This effect, the result of the combined interference of the two dissimilar frequencies, will appear to slow down the external frequency 'field' in respect to the Particles' radial wavelength expansion. (As the wavelength increases, the frequency decreases to a longer timeframe of existence) (205). This slower 'encompassing frequency field' exhibits wave properties, from the negative (less positive potential) peripheral of the Particle oscillations - to the concentrated, more positive potential, internal core.

This lowered frequency effect will result in an expansion of the affected Particles' spherical boundaries (204), each 'growing' to the size of an electron (2.817×10^{-15} cm) thus enabling the Particle, at equilibrium apogee (zero point between absorption and emission) (206) to disrupt the properties of a near-field electron.

As the energy imparted shell reaches the equilibrium apogee (19, 206), the peripheral resonance will pass into (shift) and below visible light (203). This event, from absorption to emission, occurs within 10^{-27} of a second (202).

The photo ionization rates depend linearly on the excitation intensity and the incident frequency (30), indicating that the ionization process occurs via a single photon.

A Photon Event occurs when dissimilar electromagnetic radiation frequencies encounter an Elementary Particle (Fig P). Most of the radiation continues in its original direction, until absorbed into stronger potentials, but a small fraction is scattered in other directions.

Radiant frequencies that are scattered, due to vibrations in elementary particles, are called Raman Scattering. Raman scattered frequencies are shifted, by as much as, 4000 cm^{-1} , from

the incident sequence frequencies (102) of the initial dissimilar Particle contact.

The ratio of fluorescence to Raman will be approximately $2/(T2 * \text{GAMMA})$ where T2 is the de-phasing time constant and GAMMA is the radiative rate of spontaneous emission.

The emitted frequency (22) will differ from the exciting frequency (30) by the energy of the final state, per the effected elementary particle's frequency (Photon Frequency Chart).

To an Observer, viewing a single photon event in visible light and in 'real time', this action appears as a 'blinking off and on' or sparkle. With a continued flow of photons, as illumination from a constant radiation source (sun, lamp, fire), the continuous photon events provide reflective recognition of any object the photons are contacting.

During a photon event, a single particle will absorb and reach the diameter of an electron (.29 nanometer) and exhibit electron properties in a superposition bandwidth. It will then return to its original energy size (emission), imparting energy (spurious sweeping emission frequencies) in the vortex, exhibiting negatively charged properties.

When a single photon, contacts a mass, of a dissimilar frequency bandwidth composition, the interaction results in disruption, both, in superposition and beat. The resultant vibration is given in a combination that lends itself to attraction from a higher bandwidth frequency particle, resulting in the eventually formation of Atoms, then Molecules.

The resultant Beat frequency modulation, of the two dissimilar particles' encounter; will produce resonance within the lower bandwidths of the Electromagnetic Spectrum (205, 203).

This resultant resonance can be converted to intelligent energy, as it beats and interferes with frequencies within this electromagnetic level of the frequency spectrum.

“There is only One, passing from Time to Time.”
- *Hodges' Yokohama Lecture, 1998*

Electrostatic to Electromagnetic

Electrostatic ends and Electromagnetics begin when Three Particles, of the same frequency bandwidth, join.

When three Elementary like-Particles join (called a Virtual Graviton in the grouping of Bosons), the result is the beginning of the nucleus of an Electron. This is due to the combined pulsation of each particle resulting in a property 'spin' of the grouping. Our observable universe (one-second block durations), and all of its properties and proven physical laws, begin at the Electron Level.

The only laws that presently exist in the Particle Level relate to voltage, not frequency. That is why we are 'bottom feeding' off the leftovers of the Universe.

However, this Electron Level is only a 'glass ceiling' and can be broken. We are close to a point of being able to work in the 'particle level'.

Do you think any advanced civilization would be working in strictly the lowest, slowest 'electron level'? (Even a civilization with only a 100-year jump on us). Why are we trying to communicate by 'radio' when They (if there *is* a They) are transmitting on particle/photon bands? More information in a smaller timeframe.

Within the electron, the Quarks will still exhibit their familiar traits, pulsating within a common frequency bandwidth. However, because half of them are 'out-of-phase' with the other half, the electron's total nucleus is impossible to observe at any specific time.

Let's look at two other differences, between Static (particles & gravity) and Magnetic (electrons & mass).

Very important: Gravity and Magnetics are two different things. The Earth has a magnetic field because of the physical properties of Quarks and Electrons, which is Matter.

Gravity is the attraction of singular like-Particles to a larger grouping within the same frequency bandwidth. From Quarks, up to molecules, both properties are present. But, in Particles, only Gravity is present. Particles Do Not have a magnetic field.

As much as I hate the expression, magnetic attraction, I must demonstrate that the Earth's surface resembles a magnet. Magnetic *anything*, has nothing to do with gravity. We can see the effects of magnets, so everyone assumes gravity works on the same principle. There are two big differences between Magnetic Attraction and Gravitational Attraction: Magnets have a North and South Pole - gravity does not. And you can shield a magnetic field. You cannot shield Gravity, because elementary particles will make up the shield. And any two particles, in the shield, will begin the process.

In other words, any gravity shield you physically fabricate will generate its own gravity, because the shield will be comprised of particles.

Earth's magnetic field emanates from the North Pole (magnetic +) and the South Pole (magnetic -) of the planet, due to the unjulation and shifting of the liquid (molten iron) core. This fluidic agitation actually causes the exact points of magnetic north and south to vary by 10 degrees within a 24 hour period.



Fig. 39

Something to think about: Lightning is the discharging of electrostatic buildup from a negative concentration (Earth) to a positive point (clouds). Lightning does NOT strike (emit) at the North and South poles of the Earth. As you can see from the above graphic, these regions are void of any Flux fields.

Not all planets have a magnetic field, but all have some degree of strong gravitational pull. Even the Moon has a gravitational pull and it is completely dead inside. (No active iron core, no magnetic poles, but some rotation). All matter has gravity, the strength depending on the combined amount of particle-mass energy. (A million single particles, grouped together, will attract *like* a million single magnets, not one large one.)

"The number of equations, that equal 10, is directly proportional to the number of mathematicians involved."

Electricity

Electricity is a flowing stream of electrons, through an electron rich medium.

Voltage is the measure of the strength or amount of electrons flowing through the medium.

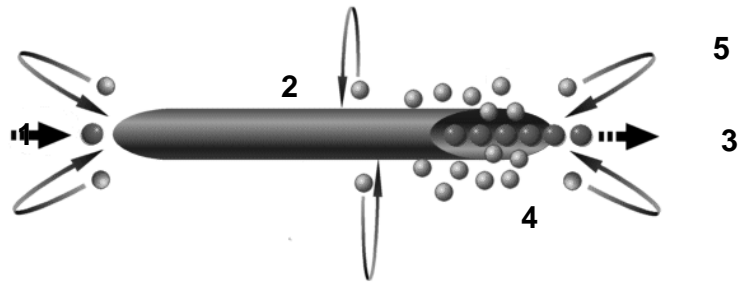

Fig. 40 Electrical Properties

I have produced a graphic (Fig. 40) that may help in an explanation of electrical properties.

A Copper Element electron is 'bumped' (this bumping could be a nudge or a slam from a 'source', depending on the force behind it) causing it to repulse the next electron 'ahead' of it (voltage).

The electrons make up the majority of the Copper wire medium.

The last electron in the wire, is pushed into a 'load' (light bulb, etc) to perform some work, from the stream of preceding electrons. How hard it is pushed is called Amperage. (If the wire is too long, the initial push, at #1, will have lost too much energy in the continuous bumping along the way, to allow the last electron to have any affect on a 'load').

As the in-line core of electrons (1-3) are pushing one another, towards the other end of the wire, non-nuclei Quarks, that are positioned 'off center' from the stream are nudged away, as a billiard ball striking another at an angle.

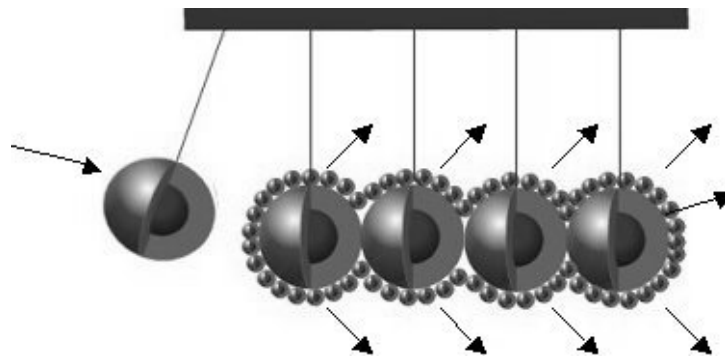

Fig. 41 Quark Reaction to Electron Movement

These incidental Quarks, having been pushed away from the main concentration of their same frequency bandwidth mass, do not have the same force behind them, as does the main stream, so they do not travel far.

They are attracted back to the mass concentration, at the points of highest exposed potentials. Points 1 (- or South Pole or Emission).and Point 3 (+ or North Pole or Absorption).

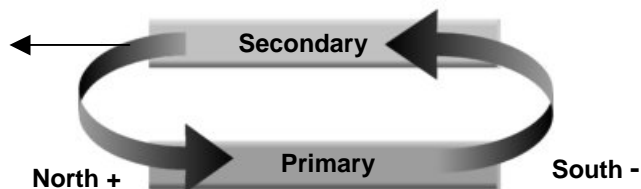

Figure 42

The strength of the Quark mass, as they are flowing back to the Poles of the Primary wire, can be strong enough to induce the Nuclei of Electrons, in a Secondary wire, to align themselves

and follow in the direction of the Quark mass path's (magnetic flux). This is Electromagnetics.

Whenever a magnetic field changes (by reversing an electron flow or by changing strength) on a primary wire, a voltage is created on a secondary wire by the Quark mass flux stream pulling along Nuclei of electrons in the secondary wire.

This is Induction, the basic principle of the Transformer.

Transformer

A Transformer is a device that takes electricity (AC) of one voltage (electron stream strength) and changes it into another voltage or voltages, by induction of alternating magnetic fields.

Transformers are used to increase or decrease AC voltages and currents in circuits. The operation of transformers is based on the principal of mutual inductance. A transformer usually consists of two coils of wire wound on the same core. The primary coil is the input coil of the transformer and the secondary coil is the output coil. Mutual induction causes voltage to be induced in the secondary coil.

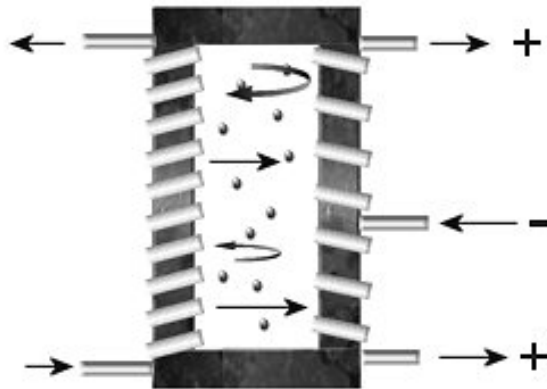

Figure 43

If the output voltage of a transformer is greater than the input voltage, it is called a step-up transformer. If the output voltage of a transformer is less than the input voltage it is called a step-down transformer.

What we are seeing, in the above graphic, are Free Electrons, being 'bumped' off the surface of the wire (Fig 41 example), as Electrons move through the interior. They begin looking for a higher concentration of Potential. If they were only slightly 'bumped', they will not travel far and return to the original wire.

However, if they were thrown off the surface, due to a strong stream of electrons (high amperage), they will travel across the 'gap' (Fig. 43) and join the flow of potential that is occurring in the secondary winding. By their joining the flow of the secondary, the voltage is modified.

This gap, filed with Free Electrons, is called a Flux or Field.

Could the same results be obtained with a Light transformer? This would involve a particle exchange of Single Quarks, not electrons.

An Electrostatic demonstration.

Hang a paper clip, in front of your computer monitor, from a thread. Space the distance to about a quarter inch.

After a few moments, the paper clip will move towards the monitor screen, touch it, then jump away.

This is due to an Electron Gun, charging your paper clip with Free Electrons (two bonded Quarks). Your monitor screen is negative, your paper clip is positive and because your paper clip cannot pull the monitor to *it*, the paper clip must move to the

monitor screen, As soon as the paper clip touches the monitor, it discharges and returns to it's normal distance.

Inflate a round balloon, rub it on your head, and hold it next to some dust. The dust jumps to the surface. Simple enough. Most know it as 'static electricity'. However, there is nothing static about it!

Rubbing the balloon on your head also created an 'electron imbalance'. (The balloon will be charged up to approximately 5000 volts!) The reason the balloon can be 'charged' by rubbing it, and the paper clip required an electron gun, is due to the materials: rubber vs. metal. The molecules in the balloon are farther apart than the metal, so it is easier to excite the free-electrons. But, you could use an Electron Gun if you so desired. A case of overkill.

The Earth is both a huge balloon and multi-blended metallic ball, made of over 100 elements. Pretty hard to charge, artificially or by rubbing.

Unless you have an electron gun the energy size of the sun!

Hang a small iron ball, by a thin string, in front of your computer monitor and leave it there for about a month or two. The first thing you may see is that it has started to rust. Much faster than if it was left lying on your desk or in a drawer.

Why? A particle-sized gravitational field has been amplified (artificially resonated) and has attracted a barrage of mixed particles, from the surrounding space it occupies. The lowest frequency bandwidth first, Hydrogen, then the rest in successive order of specific gravity, up to it's limited attractive strength. If you had a microscope that could see to the little planet's surface, you would likely see moisture (water).

And maybe the traces of a primitive atmosphere.

What else would you see? Possibly dirt. A crust being formed from 'dust-like' passing particles. If left alone for a few thousand/million years, and if there were enough unattached particles floating around (like immediately after the Big Bang), this crust would build up to a point where the iron core would not be able to vent it's own generative heat and melt inside the crust, THEN creating a paramagnetic field. Even though the little planet is not revolving, it will develop a form of magnetism.

It must be understood that, the size (mass) of the iron ball does not determine IF it has a gravitational field, only the intensity. From the moment it was manufactured, it was producing a gravitational attraction.

The Earth, even seen from as close as the moon, has a surface as smooth as an orange. All of the material that is being held on it's surface is smaller than the scale of the dust on your iron ball.

The surface material is being artificially attracted to the iron ball by the massive 'electron imbalance' and weaker electromagnetic attraction for an object its size.

Just a quick side thought: How large of a diameter is the Earth capable of achieving? If there was enough debris, still floating around us out there, from the Big Bang, the Earth could attract another 50 miles worth, with it's present gravitational holding power. But, add another 50 miles on top of what we have already and the imbalance area will grow larger, also. But, if we got any larger, our equilibrium space in the Solar System would change. We would probably be pushed farther out from the sun.

There are mathematical models that show us, if we were to construct a 'non-rotating' sphere, 3-miles in diameter, it would float. Well, anything that large would contain enough molecular

material to generate a significant electron imbalance, and will repel. On the scale of a 3-mile sphere, the Earth and the new planetoid would definitely repel each other. But, only to a distance of equilibrium. That is where the large negative repulsion of each body would no longer 'water-down' the attractive force and the two bodies would maintain positions from each other, based on their huge electron bubbles. The small sphere would orbit the Earth. It may be only 100 feet or 20 miles up, but it would be in orbit.

This is not defying gravity, but working with it.

As the sun bombards us (Earth) with additional free-electrons, supplying an artificial amplification, the elements on Earth react by gaining and throwing off these electrons, like neighbors passing on a freeloading, but very energetic, houseguest. All elements on the planet are affected; creating an instantaneous and continuous combined field that increases the effect of 'gravity'. But, it is not the cause of gravity. That goes a lot smaller.

So, where is the Center of Gravity? There is no center or main concentration. The majority of all gravitational forces are 4000 miles 'out' from the center of the Earth's core: The surface of the planet. In most cases, it has been under our feet.

Down we go. . .

Let us *imagine* a hole in the Earth. A big hole: One mile across and 4000 miles down. Right from the surface of the planet, straight to the core. (This hole thing will never be created and is just used as a brain teaser). Casually pick up a one-pound block of anything (where we stand, a pound is a pound, no matter what it's composition), and drop it into the hole. With our special viewing system, we need to imagine that, too, we see the block streaking away from us at 32 feet per second, per second. It 'drops' for miles. Then . . . it slows down. And then

stops. After a short pause it will start back 'up'. Again, gaining speed at 32 feet per second, per second.

We can stand back and watch it shoot out of the hole and into the air, rising high above us. Until, it again, drops back into the hole and repeats the process. Well, ok, this would not happen. But, the weightless properties do apply to Down, as well as, Up.

What happened here?

First of all, it was not falling towards the 'center of gravity' when we dropped it into the hole. There is no such thing. There is a 'region of maximum gravitational effect', and, unfortunately, we are stuck right in the middle of it. The region surrounds the Earth, from about 125 miles above us, to about 250 miles below us. Within this area, everything weighs what we have come to accept as 'normal'.

Earth Weights and Measures.

A pound weighs 16 ounces. The same one-pound block, 1000 miles above us, will weigh 12 oz. And, 2000 miles out, a pound will only weigh 8 oz. Traveling 4,000 miles away (up) from Earth, a pounds weight is down to 4 oz.

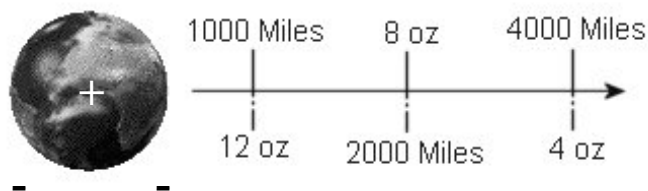

Fig. 44

Envision the Earth as a huge Particle. It is not physically pulsating, but the same reactions are taking place. The surface Particles have accumulated to a point that the mass creates an incredible negative Fuzz, trying to get to the more positive + center.

Chapter 5

"If I cannot construct something, I cannot understand it."
- R. Feynman

-Putting It All Together-

The One-Second Universe

How long is a second?

Simple question. And as most people, you would probably respond in turn, "A second is a second. Why go beyond that?"

All right, how many ounces in a pound? Here is the American rundown: 27.34 grains = 1 dram, 16 drams = 1 ounce, 16 ounces = 1 pound . . . and going the other way, down it goes until we get to the gravitational effect of two Elementary Particles resonating within their common frequency bandwidth. (We have gone through most of that, already.)

But, what about the second? It was enough to say 'fraction of a second' for many years for we had nothing that depended on a time frame smaller than a fraction of a second. The introduction of photographic processes began the need with requirements in the 1/1000 range.

Only until recently did anyone ever hear of something called a Nanosecond. (1/billionth of a second). It was known by a few number-jugglers for decades, but brought to the general public's awareness by the computer industry, in the early development years. It supplied a step, where a unit was needed to measure the distance an electron travels in a specific period of time. In this nanosecond enlightenment, it was found that the average electron travels .001 microns (10^{-3}) in that short period.

So, in order to make computers initially faster, the components on a card needed to be physically closer together. Thus began miniaturization of electronic circuits.

Well, we found a use for chopping up the second, but only we computer nerds in the Silicon Valley need to understand it, right? Wrong. The next step in Mankind's evolution will come from the periods that exist between the seconds.

As you read earlier, we can no longer advance by manipulating our present one-second, electron-affected universe, for we have reached the limits of it's offerings. We need to step into the fourth dimension of Time to begin our next technology growth phase.

It has always been there, we just have not been technologically advanced enough to see it, understand it, or use it . . . until now. I am talking of the Universe that exists in the realm of Elementary Particles.

Millisecond: 1/1000 of a second

Microsecond: 1/1000 of a millisecond

Nanosecond: 1/1000 of a microsecond

Picosecond: 1/1000 of a nanosecond

Femtosecond: 1/1000 of a picosecond

Attosecond: 1/1000 of a femtosecond

Zeptosecond: 1/1000 of an attosecond

Our physical makeup has been the result of an evolutionary process to provide us with every attribute required to successfully function upon this planet.

How much information does our brain require, and how fast does that information need to be processed, for our species to function and procreate in the physical world?

We have five senses that provide the input of information from the environment.

Senses that are at their peak of performance, after having been tuned for thousands of years. But, these senses are only suited for moving around in a One-Second Universe.

Sight: Optical inputs that process reflections of light between 300-700 nanometers. That is all we need to see things around us.

Hearing: Audio sensors that detect air wave pressures oscillating between 30 and 2,500 cycles per second. Perfect for listening for predators or a child crying.

Touch: Tactile sensors that detect textures, heat, cold and edges. Great for finding things at the bottom of a purse.

Smell: Olfactory sensors that respond to packets of gas molecules. Useful in the detection of the age of milk.

Taste: A variety of nerve filled buds that respond to specific chemical compositions.

·
"Yuck, this tastes terrible... you try it!"

What do all of these wonderful biological features report to us?

Conditions within a world that organisms need to survive.
One second at a time.

So, just how much information is actually being collected, by our senses, and how much is processed without us being conscious of the data?

Organisms are slow to react to any environmental change and most environmental changes are slow in occurring. Sensors that responded within a second were good enough.

Let's do a simple experiment.

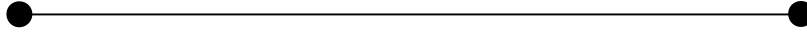

Place your gaze on the dot to the left, then scan the line to the dot on the right.

What were your eyes doing? Moving in a fluid motion?

No. They had to stop, process the info, and then move again. In a one-second scan of the line, your eyes jumped, at least 5 times.

You wanted the information, about the line, in your brain in one second. Your biological makeup had to process 5 packets of data, in that second, to accomplish the scan.

How much more data was processed at the same time, besides the image of the line?

Every sensor was working at the same time. But your Being only required 'satisfactory' reports at around one per second. Even though a million more bits of information were received, only a small amount was actually used, or seemed important, at the time.

What else could have been processed, if your Being required the information?

When you watch a movie, you are viewing a series of individual pictures, which are being flashed before you at 24 frames per second. Due to the fact that our brain cannot process each frame, at that speed, it blends each of the images together in a linear sequence of key points moving from one point to another. Our brain perceives a fluid motion of images.

What is the smallest time-period that our brain can process? Music videos flash montage images at about $\frac{1}{2}$ second intervals. We seem to be able to process at that speed. But it gets a bit too much, at times. An overload of incoming sensory data that we do not need, within that time period. The technology of image presentation has passed our biological needs or sensory capabilities.

Think of a camera shutter speed.



Fig. 45

I will be using a special Exahertz Digital Camera, with a verity of lenses, for this portion of my narrative. It is equipped with a Tamashii Engine module, for shutter capture speeds, up to 100 EHz. (100 Quintillion times per second).

The first picture (above) is of an orange, with the shutter opening and shutting in $\frac{1}{2}$ second. (Or, in keeping with our frequency thinking, .5 Hertz (Hz)).

The image of the Orange will remain the nearly the same, as above, until the shutter speed is set to 1/2998 GigaHertz.

Then it all changes.

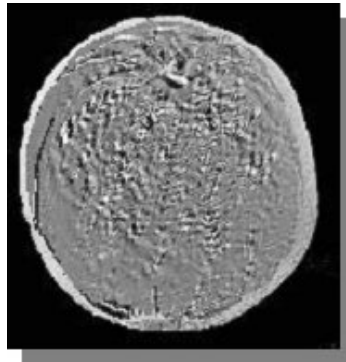

Fig. 46

This is not an x-ray or a Magnetic Resonance Image. It is a digital rendering of a photograph of an Orange, as it appears in 1/2998 GigaHertz.

Very little of the skin is visible, as the camera has captured the highest concentration of particle mass exiting, in this time segment. Seeds are visible, in various locations.

At this shutter speed, the image appears in the Infrared Bandwidth.



Fig. 47

Figure 47 is the same orange, photographed with the shutter speed set to 1/299.792 TeraHertz (THz), Upper Infrared.

How does this work?

The Tamashii Frequency Chart lists the elements, from the slowest (Hydrogen), on up - past Uranium. These listings are calculated on how many times one particle of the element, pulsates in one second.

In the case of Hydrogen: It takes 309 trillion complete energy pulsations in a single second, to be classified as a Hydrogen Particle.

With Carbon it is 3 quadrillion energy pulsations in a single second.

What if I took a picture of a single Hyrdogen (#1) particle, with a shutter speed that was faster then the particle's oscillation?

I must use my Exahertz Digital Camera, again, to graphically explain what is happening in the preceding Orange pictures.



Fig. 48

The fan, in Fig. 48, represents a Hydrogen Atom (#1), rotating at .309EHZ.

I can 'stop' the blades, in the picture, by having my digital capture speed (shutter) set to $1/.309\text{EHZ}$

The two fans, below, represent Hydrogen (#1) @ .300EHZ and Carbon (#6) @ 3.6Ehz. I have the shutter capture speed set to Hydrogen, so the Carbon fan blades (Atom) are not fully visible.



Fig. 49

Oh, did I mention that the camera takes 92 pictures, at the same time?

It captures a series of 92 individual images, each one set to the shutter speed of every element in the Tamashii Chart.

A image, consisting of 92 separate time instances of the same object.

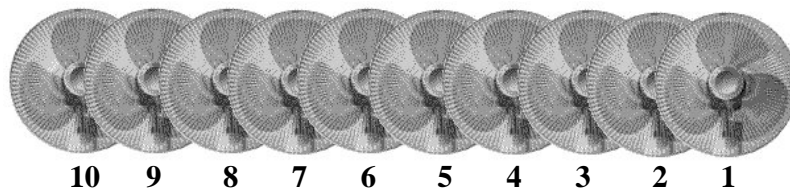

Fig. 50

Each image is an individual elemental Atom (or a grouping of the same Atoms), which exist within the target object.

If I only want to view every Carbon Atom, in the object, I tell the computer to show me image #6, and subtract any information that is in the image from #5, down to #1. It will not clearly show anything above #6. But we could tell the computer to, also, eliminate images #7, on up, to clarify image #6. It is just information. We can manipulate it, any way we wish, after it has been captured.

If we take a picture (digital capture) of a drop of water, H^2O , we would only see two images, in our series of 92. One at #1 (hydrogen) and one at #8 (oxygen). All of the other layers would be blank.

If we get the newest version, of the ExaHertz Camera, we can get well over 2000 images at once. This will show isotopes. However, that will not be available for a few years, yet.

Notice the three blades, on each fan? Those are the nuclei of each Atom. Three Quarks.

If you are not viewing the Atom at the right speed, it would be very difficult to observe the exact characterizes and

relationships of these ‘blades’. That has been a big problem, up to the Silicon Plateau.

The Tamashii Engine

As displayed in the Frequency Chart, the naturally occurring frequencies, of all Elements, reside in the exahertz range (Quintillion (10^{18}) cycles per second). And, as the Technology Pyramid (Fig. 2) shows, up to now, we were unable to reproduce these frequencies, due to our Silicon-based technology.

We now know what needs to be developed, in order to rise above the Silicon Plateau. We just need to assemble the right components.

Below is a block diagram of the Tamashii Engine.

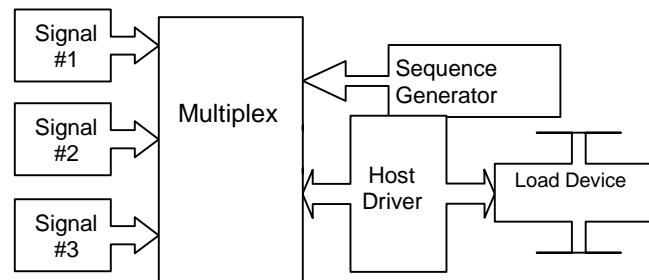

Fig. 51

Three base frequencies (Signal 1-3) are induced into a multiplexing module that sequences an output to a Host Driver, via commands from a Sequence Generator.

The output of the Host Driver, provides each off/on command for specific Load Device applications, above the Silicon Plateau.

Sounds pretty routine, but the real trick lies in the composition of each module.

In order to explain Signals 1,2 and 3, we must review some simple, basic physics of light properties.

White light is comprised of all the frequencies in the visual bandwidth, ~750 –390 nm. This sequence of frequencies can be broken down to three specific sections, or colors.

Red 750-597nm (This includes Orange)
Green 597-492nm (This includes Yellow)
Blue 492-390nm (This includes UltraViolet)

This is known as RGB (red, green and blue).

A computer monitor is able to reproduce a spot on the screen (pixel) in 16 million different colors from three frequency emitters, of Red, Green and Blue. It is just a matter of which ones are switched 'off and on', in what sequence/combination and for how long.

It must be noted that, While Light is not a specific, individual higher frequency, made from the combination of other frequencies. It is a *result* of all the frequencies, appearing at once.

[One nanometer is 10^{-9} of a meter. The diameter of a penny is 19 billion nanometers.]

Test: What are the three elements required for feeding a Tamashii Engine Array?

As you have seen, only emissions from base-frequencies are used to generate harmonic frequencies. A resultant frequency emerges from a combination of the related bandwidths turning ‘on’ at once.

The quest, for an exahertz signal generator, has been underway for decades and has become the focus of ultrashort pulse generation, in the Laser industry.

The reason that lasers seem to be a source for generating these higher frequencies is the commonality that exists between the known techniques of color generation (RGB) and the higher frequency outputs of lasers.

However, solid-state lasers have been pushed to their limits, hitting the $\sim 1000^{\text{th}}$ harmonic range. (100nm – between Ultra Violet C and Vacuum Ultra Violet). Phase matching this process might allow pulse increases of ~ 10 Attoseconds.

Attosecond science, centers on the Quantum dynamics in an atom or a molecular bond involving: atomic-size fields (volts/angstrom), times (picoseconds and below), and frequencies (terahertz [10^{12} hertz] to exahertz [10^{18} hertz]).

Due to the high power outputs, existing laser research is following a path of energy science. Basically, lots of power generation and burning holes in stuff. Ogg’s new search for synthesizing fire.

So, how do we generate 3 distinctive bandwidths, within the Exahertz range, that emulate an RGB process, without burning up the emitters and anyone standing near the device?

Photoionization is one approach. That would be to use a laser to excite the (–) negative fuzz within an Atom, to a point that ‘sparks’ would fly. Those sparks would certainly contain the frequencies we need, as does lightning. It would look cool, but

would cause havoc with other processing systems and could not be contained inside a laptop computer.

The most feasible developmental approach is to incorporate *living cells* into the emitter array. I am not talking about some Frankenstein experiments, but formulating substances that provide baseline oscillations within three specific bandwidths. The oscillations are the results of excitations of the combined atomic mass of each cell, to an order of 59 Octaves (150.81687 exahertz - 301.63374 exahertz).

In reviewing the Frequency Chart, one can see that a span of 82 exahertz exists between Hydrogen (1) and Ununium (111). To keep in line with the RGB model, this span needs to be broken down into three bandwidths, of which every *sound* of each Elemental 'color' can be reproduced.

A logical breakdown would be in three ~33% chunks.

Signal Emitter #1: .300 – 28 EHz

Signal Emitter #2: 28 – 55 EHz

Signal Emitter #3: 55 – 82 EHz

To accomplish this, three separate emitters must be identified, each having outputs that completely cover one segment of the three bandwidths.

Of course, the chances of a single material covering an entire segment's bandwidth is highly unlikely. Manufactured compounds may need to be developed to fulfill the requirement.

The Sequence Generator is required to provide programming for arranging the incoming signal information into the order, amplitude, phase and time base (duration) streams required for the Host.

I should point out that, The Tamashii Engine, is just that . . . an Engine.

It can sit and idle forever, without doing any useful work, if it is not providing drive power to some external device. Just as a transmission is required to make the wheels turn on your automobile, so it is with this engine.

Where could this Engine lead us? Replace the Elemental emitters with Biological emitters. Molecular DNA-based computers and related Artificial Intelligent software would change the world, overnight.

Radiant Energy

Nikola Tesla was born in Croatia in 1856 and spent most of his life in the United States, developing electrical devices that brought forth technologies, such as: Alternating Current, x-rays, radio, electric motors... there were 111 patents filed by Mr. Tesla, in his lifetime.

In the 1890's he moved to an isolated laboratory in Colorado Springs, with his lifelong assistant George Scherff, to develop electrical coils that could unleash power at unheard-of levels.

Below is a graphic, depicting his air-core Transformer coil design, now known as a Tesla Coil.

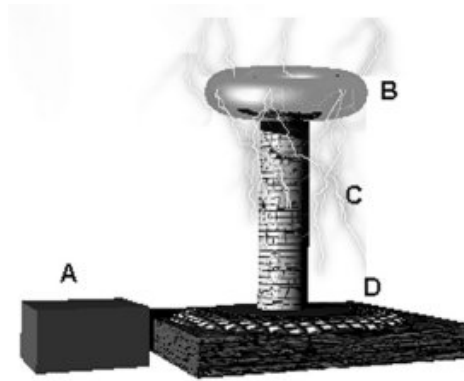

Fig. 52 Tesla Coil

The Tesla Coil is an air-core transformer, comprised of 4 basic components:

A power supply [A] provides primary energy, via a tuning circuit, to a horizontal coil of wire [D], but wound outwards, in a spiral. This coil maintains a strong (-) Negative potential to ground. It is the Primary Coil of the transformer.

A vertical, hollow tube [C], positioned in the center of the Primary coil, is wound on the outside with a specific number of turns of wire. This tube is capped by a toroidal metal casing [B].

As the power is applied to the unit, a resonance develops, between the vertical hollow coil [C] and the horizontal spiral coil [D]. This creates a frequency flux causing the Cap [B] to rise in (+) Positive potential, acting like an electron magnet.

Tesla and his assistant performed numerous experiments with these devices, building one unit, which stood 52 feet tall and generated bolts of energy exceeding 12 million volts.

His plan was to generate power with these units and transfer it, through the air, to every household. No more wires.

“Free energy for all.”

His plan almost worked, but he was thinking in the wrong direction.

The energy was already 'out there' (which he discovered in late 1900), all he had to do was bring it into a storage device. His coils could have done it, if he would have had a way of isolating specific frequencies.

When he switched his huge coils on, thunderclaps from his manmade lightning could be heard for miles. It also caused many episodes of unconsciousness for himself and George.

What was happening was, his coils acted on every Free Electron within the area, and an aggregation of particles, residing within a bandwidth from ~300 nm to ~.65 nm.

Just as the fingers of a great river all join into a great body, at the mouth, so was the 'lightning' that Tesla was drawing inward, from the air. And it pulled in all of them, especially the most abundant – Hydrogen and Nitrogen.

He and George's brains were often deprived of fuel - Free Agents of Hydrogen.

But, he had no way of 'tuning' his coils to a specific element's frequency. He needed a Tamashii Engine.

From these experiments, came the next step.

Tesla obtained a patent (U.S. Patent # 685,957) on Nov. 5, 1901 for An Apparatus for the Utilization of Radiant Energy.

This device focused on his realization that energy was already, all around us.

My block graphic (Fig. 53) is a representation of this device.

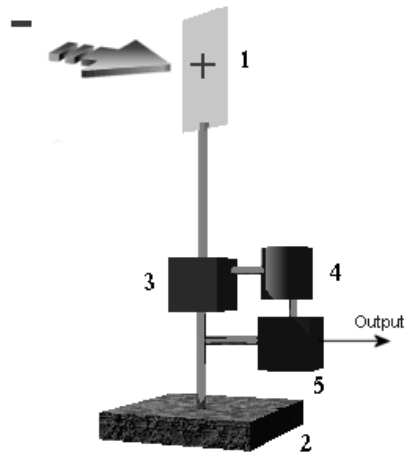

Fig. 53 Tesla Radiant Energy Device

A metal plate [1] is charged to a high + potential, by being positioned (on a tall pole) at the positive end of a mylar capacitor [3]. The negative side of the capacitor is firmly attached to the Earth (ground) [2].

Also attached, to the + potential side of the capacitor, is a 'switching device' [4] that will discharge the capacitor, at various intervals.

The systematic discharges, from the switching device [4] will feed into the primary windings of an Output transformer [5].

Wires, leading from the secondary windings of the Output Transformer, would be able to supply electrical energy to any attached load.

Rumors had it that Tesla had developed a shoebox-sized unit and attached it to an electric motor, in an automobile, and drove around New Jersey for a week.

Whether this story is true or not, it could happen.

Nikola Tesla, as with all of the pioneers I have mentioned, accumulated information on existing technology and put

together a new section of stairway, upward. And, as with Moseley, a few stairs were missing, but showed us where to look to find them.

Tesla's Radiant Energy studies have laid some significant groundwork for technology that can now be realized, above the Silicon Plateau.

And this is where we go next.

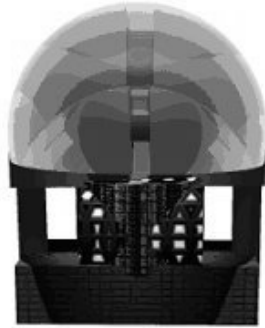

Figure 54 Tamashii Radiant Energy Device

Figure 54 is a graphic representation of a Tamashii Radiant Energy Device.

This device resulted from the basic Tesla radiant energy unit principles. Under the dome are dual, tuned receptors, linked by an array of high-voltage capacitors. These capacitors feed to ground, through two opposing coils and isolating circuitry that is specifically tuned to Hydrogen.

The cesium-coated dome enclosure houses a Helium atmosphere that accentuates the cesium 'mist' of electron bombardment, the result of Hydrogen Particles' dissimilar frequency interaction as they pass through the quartz dome to get to the + potential (Hydrogen target) path to ground.

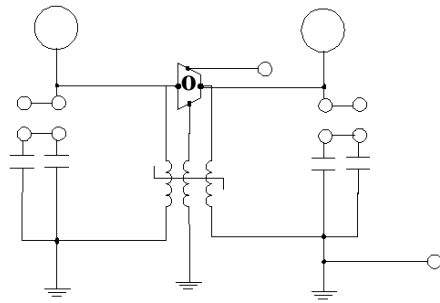

Figure 55 Tamashii RE schematic

Figure 55 is the basic schematic, representing the circuitry of Fig 54 radiant energy device. The oscillator (o), which tunes the whole unit to attract Hydrogen Particles, through the dome, is the key.

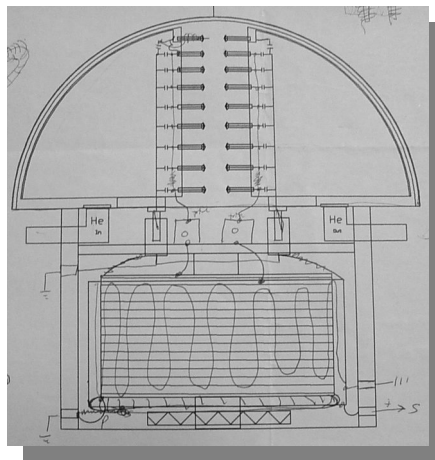

Fig. 56 An early CAD design of the Tamashii RE Unit.

Oh, if anyone asks, I have the oscillator going in for a patent.

Sorting out the Myths

Electron Level Gravity Fields

The first 'electronic' device, humans ever invented, was The Diode, or also known as the Rectifier. Of course, battery energy technology existed for thousands of years, but I am referring to direct current devices that 'work', or provide a sustained and controlled manipulation of the direct current (DC) electron flow from the negative to the positive potential of the battery.

The diode is a simple device, once you understand what the heck is going on with the like-Particles, protons and electrons that make up the atoms. (I think we now have a basic understanding of that universe).

Ever looked inside your old TV and see the 'vacuum tubes' softly glowing in the cabinet? You were seeing a piece of nickel (cathode), heated it up to around 2500 degrees F., expelling free-electrons into the surrounding space, inside the tube. Another piece of metal was close to the blue-glow (electron field) and a stream of (-) electrons were diving for the more-positive field of the new passive material (anode).

If you were touching the cathode and the anode (electrode) at the same time, you would really get a shock, as you would be the '+ ground' needed to discharge the anode (electrode) and complete the circuit. The voltage created by the amount of electrons passing over you would not do much damage, but the force generated by the electrons slamming into the electrode would create a tidal-wave of other electrons in the cathode, streaming out to find a new home. In this case, *through* your

body and back to the anode. This massive force is measured in amperage. This is what really makes electricity work for us (or kills you, if you are still holding the two pieces of metal). This is a rectifier. It is most useful in converting Alternating Current (AC) into Direct Current (DC).

The Diode is a one-way flow valve, that let the electrons to move in only one direction (- to +), and will not allow them to reverse.

Isn't the sun acting just like a huge cathode?

Yes, the Earth and every object surrounding any sun is an (-anode) electrode. The more mass it contains, the larger it's attractive force. (Even though the Earth is considered negative, it is countless times more positive than passing particles, electrons, meteors, asteroids, etc. That is why they love to fall on us). But, with no way of `discharging', unlike you holding the two pieces of metal of the rectifier, these bodies become artificially `electron imbalanced'. They must find ways of momentarily discharging internally (plasma). We can see one form of this as lightning, where it discharges around the Earth at over 100 times per second.

Everything evolves, as did the rectifier. The space between the cathode and anode ('electrode' in an Electron Destructive Machine) is called the dielectric.

If the dielectric is a 'vacuum', the electron's flow easily from one surface to the other, across the gap. If there is some other material used as a dielectric, the electron flow can change into a number of different modes and forces.

Put a piece of crystal between them, like a chunk of salt. The electrons will not be able to pass straight through to the electrode. A single electron cannot break through the salt dielectric barrier. But, have them wait for others to catch up, and `charge' together . . . they can make the jump across the gap.

This is called a capacitor.

A capacitor builds up electrons and pulses the groups of particles at once. The type of material used for the dielectric, will determine the amount of time it takes to build up a group of electrons strong enough to jump the gap.

Here's a thought: What if you were able to discharge the Earth? What would happen? Well, first of all, the entire atmosphere would escape. Anything not attached/bonded to the surface would be thrown off. Scary. But, in order to discharge the Earth, a permanent `+ ground' would have to be attached and wait for it to `drain' all of it's excessive electrons. It would take thousands of years and would be a very slow, almost unobservable process. This is due to the fact that the internal molecular structure of the planet and the surrounding solar activity would still be producing enough free-electrons to keep the imbalance going for quite a while.

But, what if a very large positive (pro+) object were to touch the surface of the Earth for an instant? The resulting discharge, and impact force, would annihilate everything on the surface for hundreds/thousands of meters and the atmosphere in the affected area would be very jumbled. The heavier molecules of the oxygen mixture would be forced to `rise' to a stronger attractive field, such as the ionosphere. There would be little

breathable air on the surface until the electron imbalance was reestablished to it's former strength and began pulling down and stacking up the molecules in their respective specific gravitates.

Poor Dinosaurs.

They suffocated. All the smaller mammals, such as the Sinoconodon and numerous aquatic species, all requiring minimal or alternate oxygen supplies, managed to survive.

Poor Humans, if it happens again.

But, let's get back to the vacuum issue.

To clear up some misguided definitions, those early electron devices were not really vacuum tubes. If the tubes had actually been a true vacuum, nothing inside would have moved. In fact, the tubes would have floated out of their sockets.

Remember this:

An Electromagnetic Wave is the crest of a wave of like-frequency Electrons, moving Longitudinal, resulting in an electric field component and a magnetic field component.

An Electrostatic Field is the accumulation of massive groupings of random Elementary Particles. They will Not emit a direction-based magnetic field associated with their oscillations, but Do emit electrical properties and Will affect gravity.

When like-electrons flow, as water flowing out of a hose, they create voltage when colliding with non-like electrons (a high pressure stream of water, out of the hose, hitting you in the face, can sting). This same flow creates amperage, when it

builds up and jumps across a gap. (The same stream can knock you down).

Of Course, none of the above would happen at all, if there were no water in the first place.

Without Elementary Particles, there would be no electrons. And, without Elementary Particles, there would be no bonding, Photon Events or gravity.

A good way of proving a perfect vacuum would be to shoot a laser through the 'vacuum' area. If there were no particles to continue the flow of the beam, nothing would be seen coming out the other side. And, again, with no elementary particles, there would be no gravity.

Wait. How would you contain your vacuum? The container itself would be composed of elementary particles, wandering around the interior, trying to seek out others of their own frequency bandwidth. (It is like trying to herd cats).

Submitted for Your Approval."

-Rod Serling

The Fourth Dimension

Relative Time. Or, why do only biological systems care about lunch time?

The last component, in our introduction of *Why*, is Relative Time. Just as one-pound is only one-pound on the surface of the Earth, so it is with one Second.

The hourglass, of long ago, worked well. A pre-measured amount of sand fell at a known rate, and when all of the sand had reached the bottom, one could assume that an hour had passed.

Obviously, it would never be used in a spacecraft, or on the moon, or any other location except the surface of the earth. But, they didn't really have to worry about that - at the time.

For their time was according to the position of the sun in the sky, or how many days were between full moons, or the time it took to grow a crop of corn. How long is that in Dog Years?

How long is that . . . really?

In our 3-D world of today, a second is 9,192 megaperiod oscillations of the Cesium atom.

What if Time did not exist?

What would be the replacement for gauging an event's beginning and ending?

'A boy dropped the ball to the floor, 3 feet below, without dropping it.'

If the ball did not actually drop, but instantly appeared on the floor, after being released by the boy, then Time would not be a factor in the action. The beginning and ending of the event did not exist in a Fourth Dimension.

The missing element is the distance (Space) that the ball would have needed to fall, to hit the floor (that old gravity thing keeps popping up). Time would have been a component, only if Space were involved.

If the boy had just placed the ball on the floor, and let it rest. Time would not be a factor, for the ball had already reached it's destination, without Time/Space being involved. The same

factors would apply if the ball already existed, and was sitting on the floor. This will be discussed in a moment.

Time and Space cannot be perceived without each other. In our discussions of Quantum properties, Time is frequency and Space is Wavelength.

Nevertheless, by removing the Space element, in an occurrence, Time should be eliminated, also.

When I ask, "What is your favorite movie?", that entire 90-plus minute sequence of images occur at once, in your mind. Every actor, their lines, the scenery, the emotions . . . There was no Time factor involved in the recall or presentation within your brain. And the 'playback' of any scene can be done instantaneously, as a packet of 'Timeless' memories. Space is not a factor. Every component required to recall the movie was in one mass, supplying all of requested data at once, from all parts.

In the world of Intelligence, there is no Space. Nothing needs to 'drop'. Everything is already 'on the floor' and Time is a playback mechanism of an events' Packet of occurrences. All requested data is accessed at once, from all parts of the mechanism.. The larger the mechanism, the greater the range of accessability.

In the technologies of tomorrow, Intelligence will replace CPU speeds, transmission rates and distances, linear events . . . reading this book.

Free-electrons are continuously falling in, around and through the protons, (momentarily imbalancing the system and

generating massive bursts of electrical , + and - energy). All of them, only colonies of like-particle elementary particles.

Try this: Take two ice-cubes and place them close to each other, but not touching. After a few minutes, you will see a puddle forming around each. Eventually they will touch and blend together. This is how the particles/Quarks blend with their neighbors. It doesn't make any difference if the two puddles are of massive differentiating elements, for free electrons have no preference. This is the bonding that gravitates all matter toward each other. However, if you move the ice-cubes far enough apart, they will no longer share the puddle. But, in the real world, it takes tremendous amounts of energy to pull large chunks of matter apart, thus breaking the gravitational effect. It is much easier to move one particle/electron/atom at a time.

"It is easier to open a door with the correct small key, than to break it down with a tree trunk."

When large deposits of any one element are together (same frequency bandwidth), they will produce enough of a gravitational field to be detected by very sensitive probes. This is one of the tricks used by geologists searching for large deposits of ore. (They still don't exactly know what 'fields' they are actually detecting, but the needle on the meter goes up.)

Diluting the Proton Field

We all have a weight problem. However, it is not something we can address by dieting.

As mentioned earlier, all matter have mass and weight. The more matter in a chunk of material, the more it `weighs'. But, what is it's true weight? That is subject to: Where it is located - at the time.

A one-pound block is one pound only on or near the surface of the Earth. Why? The attractive force between the material's tiny proton field (the positive portions of it's combined, limited amount of elementary particles) and the Earth's massive electron field (countless elementary particles, with their negative fuzz) creates a condition we call 1g (1Gravity). In this case, it is creating a one-pound pulling force on the block towards the surface. Weight is nothing more than a numbers game of who has more elementary particles. Thus, Gravitational Force.

If our one-pound block were free-floating in space (actually it would not be floating, but, continuously pulled towards the nearest Less-Negative field), what would be its `normal' weight? Nothing weighs something. The measurement would be the combined positive attractive fields of the particles within the block, relative to the largest, closest grouping of particles. Very small indeed, but never completely `weightless.' (Even though negative always moves towards positive, the positive pull, from the one-pound block, is not going to move the Earth. So, the block takes the initiative).

Why is our block's field always positive? As mentioned before, protons are the positive and neutral strings in an atom; electrons are the negative pieces that link them into becoming atoms.

There are an equal number of protons and electrons in an atom. (i.e. Helium's atomic number is $2H = 2$ protons and 2 electrons). But, even though the numbers are equal, the energy masses are not. The proton's energy mass is 1836.1526665 times larger than a single electron. (1 electron=3.5 energy mass). It has a larger positive attraction. Atoms move around each other and generate their molecular structure by `positive' repulsion. In order for a pair of atoms to be imbalanced enough to repel each other in a `negative' condition, they would need an additional negative energy mass of 2000 to water-down the strong positive effect for each proton. This is not a normal state-of-affairs for an atom.

The addition of electrons to an atom does not change the atom's molecular characteristics or change it into a different elementary component. (You can't add more electrons to Iron to get Gold). The reason: these free-electrons are only passing through. They are unable to maintain a permanent orbit.

But, what if they did? What if you had a piece of material that was artificially like-particle saturated, to a point that it's negative state was equal to the negative state of the Earth's imbalance at the surface?

Think of the things you could change.

Virtual Bonding

Bonding is the process of two dislike-Atoms, existing in separate time-frames, joining, via a Virtual Atom, to create a molecule. This process is accomplished, without a Photon Effect taking place.

What sort of Time/Space magic allowed this?

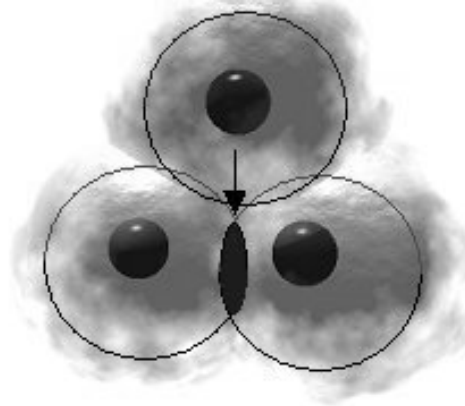

Fig. 57 The Bonding of a Water (H^2O) molecule.

In Fig. 57, two Hydrogen Atoms (red) have entered into each other's envelopes. As they are within the same Element frequency bandwidth, a Photon Effect did not occur. However, the cross-frequency resultant has created a Beat and Superposition frequency (Virtual Atom) that exists within the same Element frequency bandwidth as a passing Oxygen Atom (blue). The result is a Bonding, based on a Virtual property of Time.

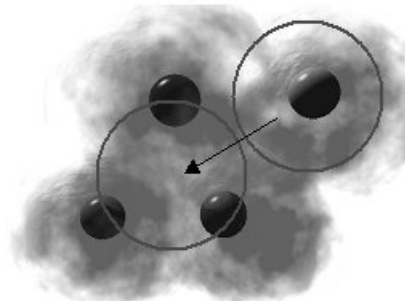

Fig. 58 An H^2O Atom attracting a Sodium Atom.

In Fig. 58, the resultant frequency, caused by the cross-frequency modulations of the 2 Hydrogen Atoms and the Single

Oxygen Atom create an additional Virtual Atom (a frequency that exists in another Element's frequency bandwidth). This Atom is within the 'Sight' of a Sodium Atom, which joins the cluster.

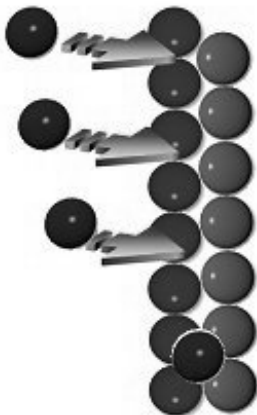

Fig. 22 Metal to Porcelain bonding.

Here is a real trick, bonding metal to porcelain.

By using a Tamashii Generator, the porcelain Particles can be resonated to create a Virtual Atom. The exact 'elemental signature' of the resulting Virtual Atom can be calculated to allow the attraction of a compatible Atom that would act as the 3rd Party target for the required Metal Atoms, to be attached. This is only the beginning of a new material processing technology.

Photosynthesis

I must touch upon a very critical process that will be involved in technologies of the future. Photosynthesis is the process that converts Photon Effect emissions to chemical forms of energy,

used by lower-level biological systems (plants, algae, and photosynthetic bacteria).

All forms of plant life convert CO₂ (carbon dioxide) to organic substances, by converting the gas to complex carbohydrates. H₂O (Water) Electrons generate the reduction reaction, which activates the conversion process, also creating oxygen and Virtual Atoms.

Energy for this process is provided by Photon Effects from high-energy bombardment (direct light sources) generating pump-like mechanisms and absorption/emission frequencies, that initiate a continuance of the Effects, causing absorption interference down in the 460-430nm and ~670nm bandwidths (the primary pigment frequencies of Chlorophylls and carotenoids/ coloration).

Chlorophylls begin absorption reactions with blue and red light and carotenoids, blue-green light interference.

Green and yellow light frequencies (650-500nm) do not initiate absorption processes of photosynthetic pigments in plants. They are of the same frequency bandwidth.

The frequencies of these colors are reflected by, or pass through, the leaves (no Photon Effect). This is why plants are green.

Well, that is about it for Photosynthesis. Basically, it is how Photon Effects initiate the pumping action that causes one cell to 'do its thing', which in turn, causes the cells adjoining it, to do 'their thing'. That 'thing', which each cell does so well (and the only thing it can do) when viewed with all of the millions of other cells around it, at the same time, is a total organism. A nice little package of pulsating frequency packets, all causing a reaction to it's neighbor that, by chance or evolution, benefits the entire organism.

So, could these same 'cells' be duplicated, by artificial means?
Yes, yep, right-o, you bet'cha, boy howdy...

It is being done, right now. And not with chemicals. With Software.

Many ask, "But, wait! Does that mean that Artificial Life is being created?"

I can only answer, "What is ones' definition of Life?"

Life forms must be able to replicate and possess a level of self preservation. This is a piece of cake, in Automa Programming. But, does a Life Form need to exist in our Time Frame, to be recognized as Life?

Synthetic Life

Since the dawn of Alchemy, the quest for creating Life has been a dark science. Unfortunately, these efforts were stifled by the lack of tools required to delve into an activity that resided in an ExaHertz timeframe.

We must envision a living cell as a molecular entity comprised of numerous atoms, of the 88 basic elements. Not unlike our Dissimilar Bonding example, unique combinations of the elements were bonded together, resulting in reactions that allowed a balanced, sustained sequence of continuance.

Not unlike a Basic software program, where the clocked sequence begins at Line 1 and performs specific actions, line by line, until it reaches the last command: Goto Line 1.

The programming of living Cells was originally built by an accident of bonding.

In 1953, Stanley L. Miller and Harold C. Urey, working at the University of Chicago, conducted an experiment to recreate this accident of bonding.

A mixture of CH_4 , N_2 with traces of NH_3 and H_2O was placed into a closed system of test tubes, with an electrical charge being continuously feed into the glasswork array.

They produced Amino Acids.

Amino acids are the organic molecules that serve as the monomers of polypeptides and proteins.

The amino acids "were not formed directly in the electric discharge, but were the *result of reactions* (Virtual Atoms) in an aqueous solution of smaller molecules produced in the discharge - including HCN and aldehydes."

Later, it was discovered, that amino acids, including Adenine, could also be made from hydrogen cyanide (HCN) and ammonia in an aqueous solution.

Adenine is one of the four bases in RNA and DNA. It is also a component of adenosine triphosphate, or ATP, which is a major energy-releasing molecule in cells.

The basic blueprint of the structure, composition of the organic monomers and the coherent behavior of a cell, had been established.

The components of these structures do not require a flow of energy for their stability; they are stable for a finite time in a suitable system.

However, without a flow of energy, the collective molecules cannot begin self-organization.

When energy begins to flow, the structure begins the creation of a collection of molecules – and a ‘container’ to keep them all safe and sound. This is called a Dissipative Structure. A semi-permeable cellular membrane.

The, now wrapped, package of molecules become a cell. And can now self-replicate, which seems to be the ultimate goal of a single cell.

The process continues until a cellular structure exists, that actually 'does' something. This is known as an organism.

It consists of a sequence of steps creating an ascending hierarchy of increasingly complex systems, from small molecules (methane and ammonia) to monomers (amino acids, purines and pyrimidines), then macromolecules, confined systems of macromolecules, and finally living cells.

An artificial cell, is known as a liposome.

And it can be emulated with Automata Software Programming.

The Cluster

When viewing a section of Stem Cells, in a high-powered microscope, you can see the aggregated mass pulsating together, as a single unit. This section of cell tissue can be encouraged to grow in a specific direction, resulting in replacement material for the heart, etc.

The cluster of cells are manipulated to synchronize (beat) their movements as a single colony, eventually taking on the properties of a heart tissue, or any other organ grouping that the sample will need to become, for surgical repair.

Each cell begins as an individual, with characteristics that can be adjusted to perform specific biological functions. These biological functions are nothing more than what reaction they cause to an adjoining cell, or grouping of cells, to perform specific actions or outputs.

This is simplistic overview of Stem Cell research, and how a colony of cells interfere with each other to actually cause

something, beneficial to the entire grouping, to occur. These techniques, employed, not only for specific tissue growth, but future Software Development, are more rungs in the ladder that will allow us to leave the Silicon Plateau.

Artificial Cells

Stephen Wolfram has demonstrated, in his book *A New Kind of Science*, a modeling program which he created with his software *Mathematica*, entitled *Three Dimensional Cellular Automata*.

Where I went with this data:

Using the frequency signatures of the elements, from the Tamashii Frequency chart data, as the base of the 3 blocks (Quarks), the prediction and emulation of frequency cell growth can occur. All the way up to Molecules.

The boiled-down explanation, of this exercise, is that an assembly of 3 blocks (an Atom Nucleus containing 3 Quarks) could be formed when exactly 2 (Nuclei of the same frequency bandwidths) of its 26 neighbors were formed in the step before.

When given Tamashii frequency chart data, as the base of the 3 blocks (3 Quarks), and entering the following type of argument for each step : A prediction and emulation of frequency cell growth can occur through the Automata sequencing.

The Tamashii program begins its processing, the program speed dependency relies upon the CPU of the generation hardware. Once a complete cell model has been developed, the program would become self generative, using the hardware as a

'membrane', while the program remains dormant, as with an Amino Acid, the components of these structures do not require a flow of energy for their stability; they are stable for a finite time in a suitable system. The artificial cells are just waiting to interference with another grouping. In other words, waiting to actually do something.

Three such programs running independent of one another, yet supplying their output (interference) to a matrix, would be the basis of The Tamashii Engine.

This could, also, be the foundation of Artificial Life, as the combined output results would emulate intercellular reactions, creating artificial intelligent sync-looping for the processing requirements of the computer running the program.

A programming structure, forming an Operating System that mimics activity of a cellular structure, through the frequency signature automata of Quark eigensystem.

Synlife output results would emulate intercellular reactions to create AI sync-looping for the processing requirements of the computer running the program. Or, feed output to another platform, level or computer, which will be a key factor in our upcoming Time Travel example.

Bio Computers

We have traveled up the Pyramid to a step that allows the integration of all of the technologies, which have been outlined, up to now.

I now present the artificial life form that sits on our desk. Living machines, capable of making a quadrillion computations on multi-levels, nearly as fast as the human brain. The first consideration, before going to the local computer store to 'adopt' one, is keeping it healthy. i.e. Alive



Once you have purchased the basic computer hardware, all you would need to replace is the Exahertz Generator Module. Everytime it died! That *could* be a crime, as some strange laws could be legislated by the time the Bio-Computer reaches maturity.

The Internet of tomorrow will resemble a hive, with each computer on the network, performing a Drone function. However, it would have the combined mentality of a million other units.

“I’m sorry, Dave. I’m afraid I can’t do that.”

-*HAL 2001-A Space Odyssey*

Artificial Intelligence

So, now we have a living computer, sustained by cellular emulation, powered by Radiant Energy and handling every mundane information task it's owner asks. IT would be very close to emulating a house plant - that talks back to you.

Getting the slippers is still the Dog's job (for now).

But, IT still needs to grow. The software, written for the gigahertz machines, it is replacing, is slow, cumbersome, linear and embarrassing.

To the computer, present day software architectures would be like trying to run, while waste deep in water.

This living machine functions on instinct, thinks in Packets and interfaces to other life forms. However, does it possess curiosity, anger or jealousy?

IT would have a Hive mentality, no different that ants or bees. And this is exactly how the first offering of this technology would be applied. In networks. Linked to thousands, millions, of other units. A global Hive of creatures totally devoted to information processing.

Hmmm... Is that a good thing?

“When this baby hits 88 miles per hour, you’re gonna see some serious” - *Doc Brown BTTF1*

Time Travel

When we reached the upper level of the Figure 1 Pyramid, we left the world of electrons and entered into an era of technology development that falls deeply into the laws of Einstein’s Time and Space.

Think of this little scenario.

You want to build a Time Machine. Ten minutes after you sit down, with paper and pen, or on the keyboard, you have it solved, because if *You* were meant to be the one that developed the device, *You* will know within moments. How?

The *Future You* would have back-engineered the device, constructed the plans and sent them back to the *Present You*, from the Fifth Layer of the Pyramid graphic.

Not only would you obtain the Time Manipulation technology, but everything beneath.

Confusing? Far fetched? Not at all.

But, would the *Future You* physically appear in your time period to provide this information?

Probably not.

This information would, most likely, appear on your computer monitor or show up as a file. But, don’t expect this feat to occur within the next few weeks. The computer, that would be

required to provide this service, is years away and will be operating on a Bio level.

How can we begin experimenting in Time Travel?

In order to take our first step, into this realm, a tool will be required to shuttle our information gathering baskets, there and back.

The Human mind has great difficulty in comprehending the concept of Time Travel. First, it must be noted that, it may be physically impossible for a human to travel either forward or back, in Time. However, it may be possible to send and receive information from both directions.

In order to bring you, my faithful reader, into this mind-boggle, we will start with a few simple analogies and thought-problems.

Look into a mirror. What you are seeing is an image of yourself, as you were a few nanoseconds ago. A video camera, attached to a monitor, may provide an image of you from one to three seconds ago.

Talking into a microphone, in a large arena or by a satellite delay, will provide you with an audio representation of yourself, in the near distant past. Trying to listen to the speakers and talk, at the same time, is quite a chore, as you will find yourself slowing down your speech, trying and catch 'down' to the words streaming from the output.

We, as life-long residents of the Information Age, really have no problem in interfacing to the past. Expect that we always want to change it. Enough of our present-day environment has incorporated visual and audio mediums, with their associated delays, to where it is commonplace for us to deal with these time shifts and phasing. Although, very primitive bush tribes

are taken back by this concept. The technology needs to be understood first, before an explanation can be accepted.

Western cultures have grown up with TV, radio, photography, and most recently, computers, to where an explanation of all of the steps and operations involved in bringing the past to us, are not required for us to accept the output. To bring a bush tribe, up to speed, on how a voice emits from a speaker, or an image appearing on a TV, would appear as magic.

But, what about going forward in time?

I need to get back to the bio-computer, and configure it to be in two places (in time) at once.

Below, is a monitor, attached to our bio-computer. It is split into two sections, each displaying one half of the total circuitry. In essence, there are two machines in the same box.

Through the Artificial Intelligent software, we will command the #1 Unit to display the current time, down to a millisecond at the bottom of the screen. It also will report the current time and any other information, on #2 Unit, in the center of the screen.

We tell #2 Unit to generate a random number and report the 'time stamp' when it has finished. After it has achieved this task, do it again, at half the speed.

As #2 begins it work, we should be able to see the time-stamp reporting quicken.

I should mention that, on top of the monitor is a small digital camera, capable of Ehz shutter speeds.

The last command, to #2 Unit, is that the very moment it passes #1 Unit clock, take a picture of You, sitting in front of the computer.

The question is: Will you be there in the picture, from the future?

Perhaps not all of you. Your biological material would still be streaming in from the time period before.

However, what does appear is the timestamp from #2 Unit, in the future.



Teleportation

Teleportation will not be the transfer of actual matter, but the digital blueprinting of every particle, and its position, in the original object and transferred to a Constructing device. This is done with a type of Tamashii Scanner (life frequency scanner).

A similar Scanner will receive the data stream and reassemble the information by generating the appropriate particles, in their position. No different than sending a .gif.

But, the 'copy' will need to be assembled in an enclosure, which will be filled with an atmosphere, resembling that of Chloride. It may be a non-destructive transport mechanism, but it will kill.

Not just the reassemble chamber, but the very fact that Life Frequencies can not be transmitted.

Life Frequencies

Picture a Sports Stadium, on a warm, cloudless evening. Inside are 50,000 people, waiting for the event.

Positioned 500 feet overhead is a microphone, attached to an oscilloscope. For an hour, the crowd's combined noise (din) is recorded and analyzed and reduced to a single modulating line on the scope. The result is a single frequency signature of that stadium, on that specific night, with a specific assortment of 50,000 individuals. (just like the one note bell).

The next evening, same weather, same stadium, but a new crowd of 50,000 individuals. The microphone and oscilloscope again perform the single frequency procedure, but this time, a new signature is created.

The two frequency lines are converted to sequence digital numbers, as displayed below:

Stadium Frequency Signature	
#1	10101001011100101001011101
#2	10101001011100101001010111

Let's break down the sequence, from Signal #2.

10101001011100101001011101

The first four digits are the Stadium acoustics, and both signatures, #1 and #2, are the same.

The next four digits could be the weather/atmospheric variables on the signals. Both are the same.

The signature can be continually broken down into 4 digit chunks, and both sequences will reflect the same imprint, until the last 4.

The last 4 represent the difference in the individuals within the Stadium, upon the two separate occasions.

In order to make this relevant to what I am trying to get across, we need to go into the future, perhaps 40 years.

It is the first day of school for a group of 5 year-olds and they are standing in line, as well as twenty 5 year-olds can stand in a line, waiting to be seated, one at a time, in a booth.

Each child is patiently instructed to sit in the booth's chair and watch a short video about 'recess rules' (or something). After 3 minutes, out they come, and another goes in.

What is actually happening is that each child is being scanned, or listened to, by a device that produces a signature, very close to our Stadium Signature Frequency.

However, this is each child's Life Frequency.

The resulting digital number, from the scan, is a bit longer than that of the Stadium. But, the breakdown is in a similar pattern.

Life Frequency Scan	
Subject: Jane Doe	
DOB: 7/12/48	
Scan Date: 9/4/53	
Pacific Breeze Elementary School	
Resultant:	10101101000100110101010000 10110101011001010001011010 101100101011010100101

Each line, in the Resultant, can be viewed as identifiable, historical, unchanging components, within Jane Doe, as in the Stadium Signature example.

Line 1: Human – DNA category 64 (etc)

Line 2: Female – Class 20 Cranium (etc)

Line 3: Combined output of all automatic cell processes within the brain, breathing, heart control; as well as, all permanent abnormal characteristics residing within parameters set for Line1 and 2 chemical and biological functionality.

This last line of code personalizes little Jane Doe's Life Frequency identification number. It is different from any other human, alive, by a factor of 50 quadrillion to one.

This entire 3 line sequence of digital numbers will identify, track and account for every action she performs, for the rest of her life. As well as, dictate how she will spend her time, alive.

Until another physical transceiver is born, with the same Life Frequency. Chances are 50 quadrillion to one that another will not exist in her lifetime.

Who would not have a Freq Number? Obviously, everyone born after the implementation of governmental Administrative requirements, would have been scanned and recorded.

The technology, that would allow the *masking* of such numbers would also be available. Accessible to politicians, world leaders, movers and shakers. Or, anyone else with the resources or positions requiring such a service. For good or bad reasons.

The Life Connection

Each living entity can be viewed as a discrete radio receiver. Each having the ability to receive 'signals' that exist within a very specific, very narrow, bandwidth that exists throughout the Universe. This includes every living organism. I am not going off my rocker here. I would like to share with you a fascinating level of Quantum, that few have imagined.

The Life Frequency number is based on the sophistication (complexity) of the organism.

Remember the lowly Quark? Filling every nook and cranny of the Universe, looking for a partner, so it could grow into a Free Electron?

You will not find any Quarks above 85 EHz. Only pure frequencies, existing so fast, without Space, that they cannot form into a single Particle. These frequencies are Life.

In a comparison, an 85 EHz frequency band is like a deep ocean, when placed alongside a 98 EHz frequency speed boat.

Group 4	100 EHz	Mammals
Group 3		Birds
		Reptiles
Group 2		Insects
		Mollusks
Group 1	85 EHz	
		Algae
		Bacteria Automata

All numbers for illustration purposes only.

But, like the ocean, the slower frequency band can cover more 'area', at once. And so it does, supplying life frequencies to billions of insects and other lower life forms.

I shall begin with the lowest (simplistic) of life forms, Bacteria.

When artificial life is created, through Automata Programming techniques, it will closely resemble this organism. Simple cells, reacting to Photon Events, producing counter-reactions that form a chain of events, which prove favorable in the continuance of the colony. But, these organisms are dumber than a rock.

Biological entities, from 85 EHz to ~90 EHz are considered Colony organisms, or Group 1. Nothing more than millions of carbon copies of themselves, serving one purpose. Often beyond our understanding of what the heck that purpose is....

Organisms, from the 90 EHz level to ~95 EHz, are Group 2 and can be considered to be of a School or Hive mentality. If we could detect the frequency band of a number of these members, from one of these groups (ants, for instance), we would see that each was 'built' with basically the same components, but performing countless individual tasks to serve the Whole. However, they would all appear to be a matched set of 'identical' radio receivers, all tuned to the same frequency. And not one individual among the entire group.

For this discussion, Group 3 creatures can be considered 'intelligent' as they possess, at minimum, nurturing of their young characteristics and some form of singularity awareness.

Group 4 members are Mammals. Presumably, the owners of the highest recognized intelligence, on the Planet. And the possessors of the highest life frequency bands, known to date.

Life Frequency Bands can only handle 'one entity' at a time. Whether that entity be a billion identical carbon copied ants, bees or flowers. Or a single Group 4 Mammal. As the Life

Frequency gets higher, the more sophisticated the 'receiver' has to be constructed. Mainly the brain structure.

Humans, at 100 EHz, are the best biological mechanism, that this planet has ever produced, and privy to a most amazing benefits of the highest Life Frequency properties.

I talked, earlier, about Space without Time and how frequencies, above 85 EHz do not have the ability to form into conventional Quarks. To put it into a visual, think of a fine mist covering everything, and continuing out to Space. This mist does not have an origin, so it is not coming out of anything, or defined to a single area. Each resonating Particle, of the specific frequency involved, is sharing the (-) negative potential with a like-resonating Particle, of the same frequency bandwidth. However, the physical spacing between each Particle could be hundreds, thousands, even millions of miles apart. But, they are still linked, and act as one Particle. I suppose, in a technical abstractness, if the 6 conditions of a Quark are met, one could have a single Quark billions of miles wide, oscillating at a single resonate frequency.

Wait! Maybe that is what is happening!

It could be, that Life Frequencies are the Grand Daddies of all Quarks.

But, what do they do?

They transmit intelligent information to Life Forms, whose biological makeup provide a receptive platform.

The Human Transceiver

So, now we now are aware of the fact that each one of us are as different from one another as snowflakes. And in more ways than just facial features, hair color, race, fingerprints... souls.

Each of us are, an individual Universe. Every one of us has an incredibly sophisticated life frequency structure. The most sophisticated of all life forms on Earth. And we are all connected through a very narrow bandwidth, in the Exahertz frequency range.

The Human body is a great Transceiver (think of a two-way radio), although, highly refined in the reception rather than the transmission. Although, many have trained, either through religious disciplines or on their own, to amplify this ability.

What are we receiving? The chances are pretty good that we are receiving skills, mannerisms, traits and vague recollections of past lives.

Let's go back to the children, being scanned on their first day of school. Their Life Frequency numbers are stored in database and everything about these individuals is recorded, throughout their lives.

Suppose this database stays active for 300 years, then one day . . . a child appears, who is associated with a specific Life Frequency number that was, also, one of the those children, 300 years ago.

Would they look the same? No. Physical attributes have nothing to do with the Life Frequency number.

Would they act the same? No. They could be the opposite sex or an entirely different nationality or race.

What would be the same?

The innate skill sets. The ability to perform a talent, that was never taught to them. Mathematics, music, painting . . . the list is long, and we have seen it happen. *Very* often.

These ‘child prodigies’ can not relate any specifics on their special skills, for they really do not know. The reason for this is that, during a lifetime, skills become second nature or ‘burned into’ a being. The average daily memories do not. So, there are no specific memories, of any past lives, that accompany a skill set, to another identical Transceiver.

I said ‘specific memory’ of a past life. If you (and you probably do) have an exact Life Frequency number of another person, who lived in the past (just the past? – hmmm), you picked up some skills, of which you never received training. But, every now and then, certain feelings or vague memories come to you. . . This is a fact. And how many past lives could have contributed to your talents or vague memories? All you need to do is count back and determine how many generations of Humans have been on this planet. You could be carrying around a whole auditorium of past lives. Think of the skills that you have not tapped into, yet.

Makes you want to get off the couch and try some things.

Soul Storage

I have covered some basics on Life Frequencies and the mechanisms that come into play in retrieving them. I suppose the next step is: How can we store them?

A biological material, capable of being ‘tuned’ to an exact Frequency, could be employed to act as a storage medium for Life Frequencies.

Am I suggesting that a Soul could be stored, until another body came along or the original body gets overhauled, then put back? Well, I have suggested a lot of things, in this book, and most *will* come to pass.

How could something like this Soul Storage medium be utilized?

Piloting space craft, on multi-year missions or robotic colonization of other planets.

Providing the intelligence for permanent deep-sea exploring robotic systems.

Placing condemned prisoners into useful, utilitarian maintenance units. (A lawnmower that mows the medians of highways – forever).

I am sure you can come up with a few hundred, of your own.

Chapter Six

Speculations and Observations

Ghosts

Ever catch an image of something, out of the corner of your eye? You turn quick, it is gone.

How about all those digital pictures that show a strange fog or image, that you know was *not* there when you took the picture.

Why does every civilization on Earth, believe in Ghosts?

I will approach this subject in the same fashion as the rest of the book has been bounding along. It's all about Time.

You should now be fairly versed on the inner-workings of Particles, Life Frequencies and the Human Transceiver. And you should now be one of the world's foremost conversationalists on the subject of the Intelligent Universe. (I can only hope I explained it well enough for you to pass it on).

Here is a summary:

Energy cannot be destroyed. Particles are individual packets of specific-frequency, resonating energy, that can only enter our Reality (in the One-Second Universe) by either: colliding with a dissimilar frequency mass, or collecting into Quarks, Electrons, Atoms, etc.

We (all living things) are an accumulation of these packets. We resonate at a specific frequency (Life Frequency) that is the resultant of those billions of packets. Our Souls are energy.

Thus: Our Souls can never be destroyed.

OK, so what are Ghosts?

They are specific-frequency packets (Souls) that have:

- 1: Collided with a dissimilar frequency mass (maybe it is *your* frequency that it has collided with).
2. Been received by a target , which was created to allow a ‘reception’ of that frequency bandwidth.

A target can be formed by either a strong, closely-tuned ‘receptor’, or through a localized electromagnetic radiation fluctuation in the upper Exahertz range. (This could actually be built).

What is a Receptor? It could be any biological or electromagnetic unit that is closely-tuned, or can be fine-tuned, to a specific bandwidth in the Exahertz range of frequencies. This can also, be another Human, either by choice (practice) or by accident. Or, two Humans, within close proximity of each other, causing a Virtual Frequency between them, that is receiving the ‘ghost frequency’.

Ever try to tune in a radio station that is almost out of range? You can almost get it, but it seems to be just on the cusp of being a strong signal. This is what is happening, when a Ghost ‘appears’. Something or someone has a frequency, or is generating a Virtual Frequency, that brings the ghost to just the cusp of being ‘tuned in’. If it were the *exact* frequency, there is a strong chance that a ‘possession’ could occur. Like two radio shows playing, simultaneously, on the same frequency band of your radio.

There has been a lot of talk and speculation on a phenomena known as ‘Shadow People’. From all of my research and interviews of individuals, who have encountered these ‘beings’,

it appears to be on the same level as Ghosts. Although, *Evil* seems to be lasting impression of a Shadow Person meeting.

Let me put some pieces together.

Humans, whose biological transceivers are specifically tuned to the Group 1 life frequency bandwidth, can detect Ghosts of other Humans, in the same bandwidth. Understandable.

People also witness Shadow People. Although, many report that these entities appear in other life forms, but always a Mammal.

Ok, that is still Group 1.

No one ever sees birds, bees, lizards or fish ghosts.

All Ghosts seem to be dressed. Many in the clothes they were wearing when they passed on. (That one is a bit odd, as there is nothing scientific about it, and it always sends me back to the archives and computer).

Shadow People are just shadows, no clothes (maybe a hat?!?). I would accept these sightings as being in line with a real ghost encounter. Evil? I would attribute that review to the witness. If the person, who experienced the ghost/Shadow, was the actual cause (Target/transceiver) of that frequency mass appearing, the cross-frequency modulation of both participants would probably cause a feeling, not unlike evil or 'fingers-on-a-chalkboard', to the witness. Plus, it would be quite frightening, amplifying the whole experience and slowing relative time to a crawl.

About the Author

Professor j.Newcombe Hodges has been one of the foremost leaders in new technology and innovation for decades.

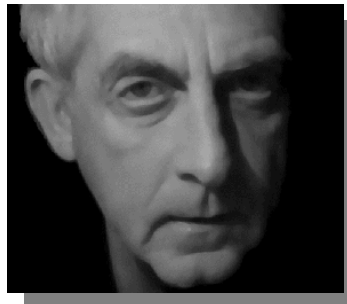

Beginning with his founding of Hodges Robotics Intl Corporation, in 1978. There, he developed numerous semiautonomous robotic systems, under full computer control, for application work in aerospace, oceanic exploration, entertainment and nuclear. Building the mobile robot that first entered the crippled Three-mile Island reactor, he quickly expanded these systems for work in bomb-squad operations, fire fighting and space exploration applications.

As if he was not busy enough, in 1985, he was called upon to manage R&D operations for automated, computerized robotic applications in building the stealth B2 bomber aircraft. While working with NASA on modifications to solid-rocket fuel housing, abatement-material applications, he developed the Mars Clock.

His entertainment projects, during this period, can be seen in many theme parks and motion pictures, today. Jaws, Star Tours, E.T., Ghostbusters . . . the list is very long.

Since 1990, he has been lecturing, instructing and developing technology to aid in the modification and repair of Nuclear Power Plants in Spain, Taiwan, Japan and France.

His ‘Fortune 500 company-focused’ lecture and consulting schedule, for 2002 includes: New Supply Chain Technologies in South Africa, the UK, Taiwan and China. Air Cargo tracking systems in Singapore. Innovation of present technologies in France. You will, also, find him in England, researching ancient texts and sites for a *special* project.

Today, while lecturing and producing a year-long series of radio programs, he remains very active in the world of new technology introduction and application. Most of his time is spent between Asia and Northern California. Some of his recent innovations: Plasma bonding, micro electrostatic generators, bio-based laser frequency modulators, hydrogen/oxygen separators, desalination processes, counterbalance gravity systems and elemental particle storage registers.

Already responsible for patents in software, electrical and mechanical developments, he is about to give the world his next series of innovations: Tamashii-based products.

j.N. Hodges has been a main guest on “Coast-To-Coast AM” with George Noory.

Postscript

It has been difficult, keeping the content (of this book) on the reality path, as so much of the information could easily be slid into the Science Fiction ditch. I want this book to be taken seriously, so the more experimental results, graphics, historical records and photos I can incorporate into my rambling dissertation, possibly, the more it will be accepted as, not only a roadmap to post-700GHz technology, but a guide to developing the next breakthroughs.

j.H. Hodges

Tamashii – A PRIMER FOR TOMORROW

The Future Frontier

Tamashii – A PRIMER FOR TOMORROW is a blending of the metaphysical and the scientific, as frontier technologist and robotics expert, J.Newcombe Hodges, discusses an array of topics, including: Quantum Systems, Teleportation, Gravity-Push engines and Life Frequencies.

“There are things happening in a quadrillionth of a second we can’t even imagine.”

Covering the growth of technology, from the discovery of Fire, to the year 2120, where Robots are designed and built with biomaterials for initial explorations of the Solar System and cancers are ‘turned off’ with TeraHertz frequency matching.